

Installer manual
CTC CombiAir

6, 8, 12, 16

Air/water heat pump

Table of Contents

1 Important information	4	9 Alarm list	51
Safety information	4		
Symbols	4	10 Accessories	52
Marking	4	Ground stand	52
Serial number	4	Wall bracket	52
Recovery	4	Condensation water pipe - KVR	52
Environmental information	5		
Inspection of the installation	6	11 Technical data	53
Indoor modules	7	Dimensions and setting-out coordinates	53
Control modules	7	Sound levels	57
		Technical specifications	58
		Working area	60
2 Delivery and handling	8	Capacity and COP	61
Transport and storage	8	Output with lower fuse rating than recommended	63
Assembly	8	Energy labelling	64
Supplied components	11	Electrical circuit diagram	69
Removing the covers	12		
Removing the front panel	13	Item register	77
Removing the side panel	14		
		Contact information	79
3 The heat pump design	15		
General	15		
Electrical connection	22		
Sensor data	25		
4 Pipe connections	27		
General	27		
Pipe coupling heating medium circuit	27		
Pressure drop diagram	28		
Pipe connections flex hose	28		
Docking alternatives	29		
5 Electrical connections	30		
General	30		
Connections	33		
6 Commissioning and adjusting	41		
Preparations	41		
Filling and venting	41		
Compressor heater	41		
Start-up and inspection	42		
Readjusting, heating medium side	42		
Adjustment, charge flow	42		
7 Control	43		
8 Disturbances in comfort	44		
Troubleshooting	44		

1 Important information

Safety information

This manual describes installation and service procedures for implementation by specialists.

The manual must be left with the customer.

This appliance can be used by children aged from 8 years and above and persons with reduced physical, sensory or mental capabilities or lack of experience and knowledge if they have been given supervision or instruction concerning use of the appliance in a safe way and understand the hazards involved. Children shall not play with the appliance. Cleaning and user maintenance shall not be made by children without supervision.

Rights to make any design or technical modifications are reserved.

Symbols



NOTE

This symbol indicates danger to person or machine.



Caution

This symbol indicates important information about what you should consider when installing or servicing the installation.



TIP

This symbol indicates tips on how to facilitate using the product.

Marking

CE The CE mark is obligatory for most products sold in the EU, regardless of where they are made.

IP24 Classification of enclosure of electro-technical equipment.



Danger to person or machine.



Read the User Manual.



Read the Installer Manual.

Serial number

The serial number for CTC CombiAir can be found on the side of the foot.

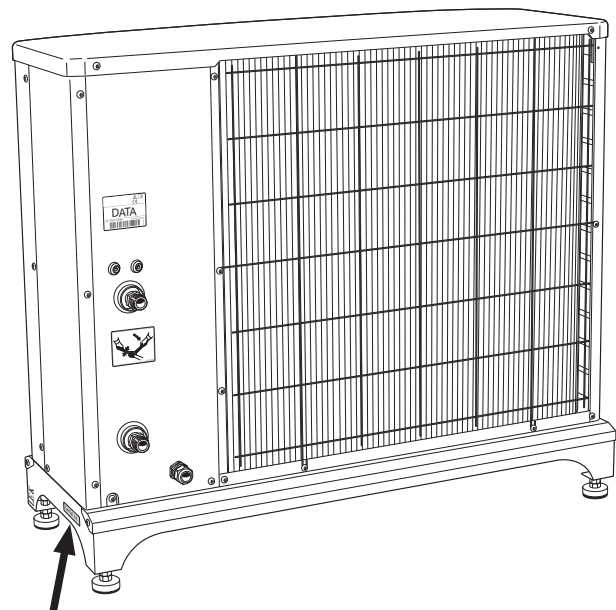

Serial number



Caution

You need the product's (12 digit) serial number for servicing and support.

Recovery



Leave the disposal of the packaging to the installer who installed the product or to special waste stations.



Do not dispose of used products with normal household waste. It must be disposed of at a special waste station or dealer who provides this type of service.

Improper disposal of the product by the user results in administrative penalties in accordance with current legislation.

Environmental information

This unit contains a fluorinated greenhouse gas that is covered by the Kyoto agreement.

The equipment contains R410A, a fluorinated greenhouse gas with a GWP value (Global Warming Potential) of 2088. Do not release R410A into the atmosphere.

Inspection of the installation

Current regulations require the heating installation to be inspected before it is commissioned. The inspection must be carried out by a suitably qualified person. Fill in the page for information about installation data in the User manual.

✓	Description	Notes	Signature	Date
	Heating medium (page 27)			
	System flushed			
	System vented			
	Particle filter			
	Shut-off and drain valve			
	Charge flow set			
	Electricity (page 30)			
	Fuses property			
	Safety breaker			
	Earth circuit-breaker			
	Heating cable type/effect			
	Fuse size, heating cable (F3)			
	Communication cable connected			
	CTC CombiAir addressed (only when cascade connection)			
	Connections			
	Main voltage			
	Phase voltage			
	When installing CTC CombiAir, check that the software version of the indoor module/control module is at least 2020-06-01.			
	Miscellaneous			

Indoor modules

CTC EcoZenith i360 H/L
3x400 V, 3x230 V, 1x230 V

Control modules

CTC EcoLogic M, L
1x230 V

2 Delivery and handling

Transport and storage

CTC CombiAir must be transported and stored vertically.

Assembly

- Place CTC CombiAir outdoors on a solid level base that can take the weight, preferably a concrete foundation. If concrete slabs are used they must rest on asphalt or shingle.
- The concrete foundation or slabs must be positioned so that the lower edge of the evaporator is at the level of the average local snow depth, although a minimum of 300 mm.
- The CTC CombiAir should not be positioned next to sensitive walls, for example, next to a bedroom.
- Also ensure that the placement does not inconvenience the neighbours.
- CTC CombiAir must not be placed so that recirculation of the outdoor air can occur. This causes lower output and impaired efficiency.
- The evaporator should be sheltered from direct wind, which negatively affects the defrosting function. Place CTC CombiAir protected from wind against the evaporator.
- Large amounts of condensation water, as well as melt water from defrosting, may be produced. Condensation water must be led off to a drain or similar (see page 10).
- Care must be exercised so that the heat pump is not scratched during installation.

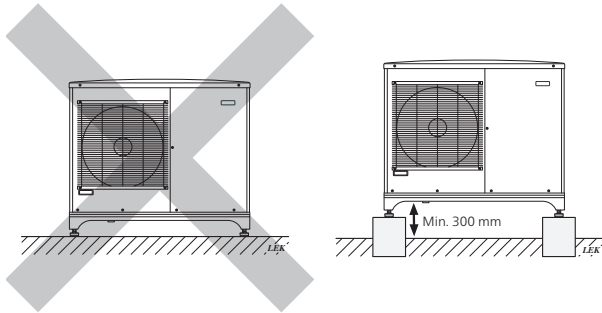

Do not place CTC CombiAir directly on the lawn or other non solid surface.

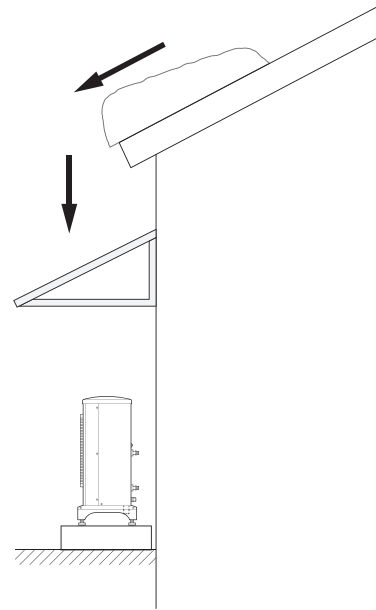

If there is a risk of snow slip from roof, a protective roof or cover must be erected to protect the heat pump, pipes and wiring.

Installation area

The distance between CTC CombiAir and the house wall must be at least 150 mm. Clearance in front of CTC CombiAir should be at least one metre.

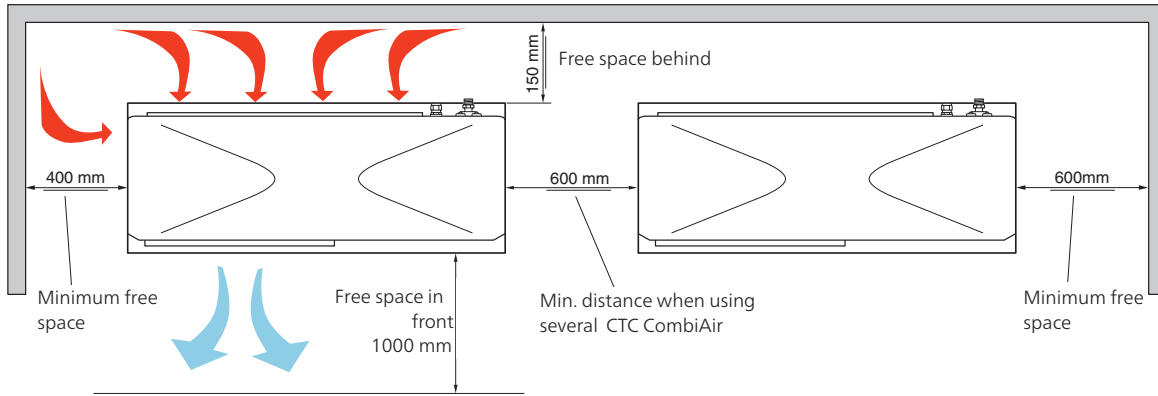

Condensation water trough

The condensation water trough collects and leads away most of the condensation water from the heat pump.



NOTE

It is important for the heat pump's function that the condensation water is led away and that the outlet for the condensation water pipe (KVR) is placed so as to prevent damage to the building.

Condensation runoff should be checked regularly, especially during the autumn. Clean if necessary.



NOTE

Pipe with heating cable for draining the condensation water trough is not included.

To ensure this function, the accessory KVR should be used.

KVR= Condensation water pipe



NOTE

The electrical installation and wiring must be carried out under the supervision of an authorised electrician.

- The condensation water (up to 50 litres/24 hrs) that collects in the trough should be routed away by a pipe to an appropriate drain, it is recommended that the shortest outdoor stretch possible is used.
- The section of the pipe that can be affected by frost must be heated by the heating cable to prevent freezing.
- Route the pipe downward from CTC CombiAir .
- The outlet of the condensation water pipe must be at a depth that is frost free or alternatively indoors (with reservation for local ordinances and regulations).
- Use a water trap for installations where air circulation may occur in the condensation water pipe.
- The insulation must seal against the bottom of the condensation water trough.

Recommended alternative for leading off condensation water

Stone caisson

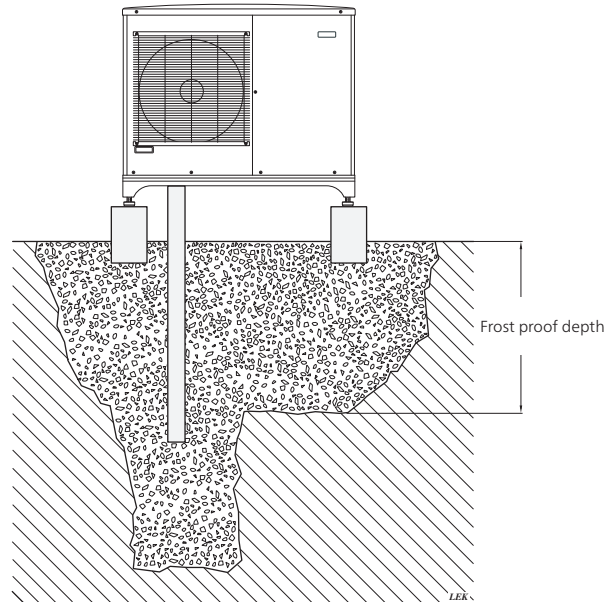

If the house has a cellar the stone caisson must be positioned so that condensation water does not affect the house. Otherwise the stone caisson can be positioned directly under the heat pump.

The outlet of the condensation water pipe must be at frost free depth.

Drain indoors

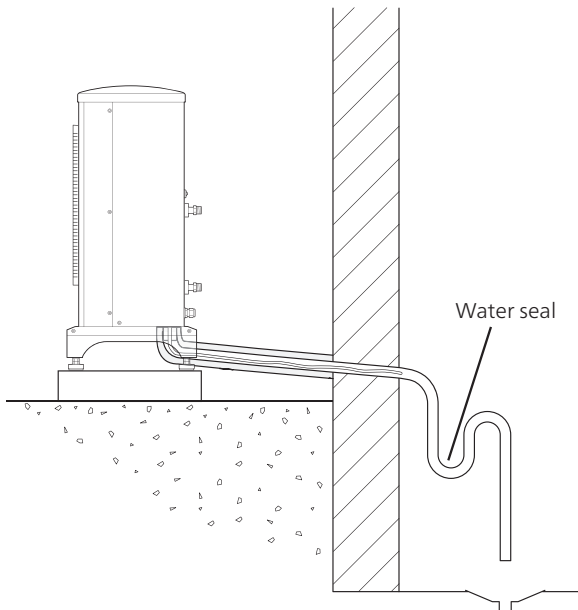

The condensation water is lead to an indoor drain (subject to local rules and regulations).

Route the pipe downward from CTC CombiAir .

The condensation water pipe must have a water seal to prevent air circulation in the pipe.

KVR are spliced as illustrated. Pipe routing indoors is not included.

Gutter drainage

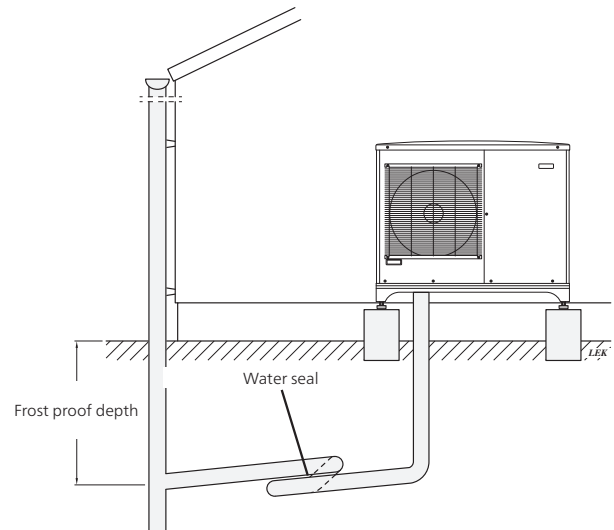

The outlet of the condensation water pipe must be at frost free depth.

Route the pipe downward from CTC CombiAir .

The condensation water pipe must have a water seal to prevent air circulation in the pipe.



Caution

If none of the recommended alternatives is used good lead off of condensation water must be assured.

Supplied components

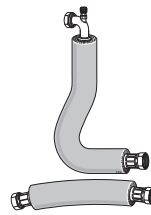

2 x flexible pipes (DN25, G1") with 4 x gaskets.

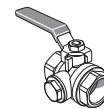

Filterball (G1").



1 x communication cable

Removing the covers

CTC CombiAir 6

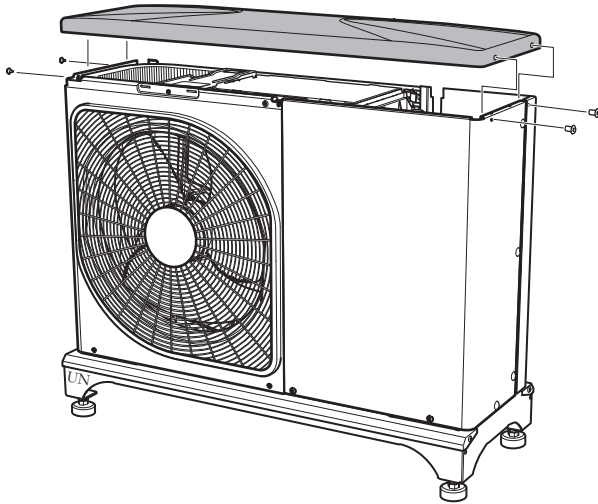

CTC CombiAir 12

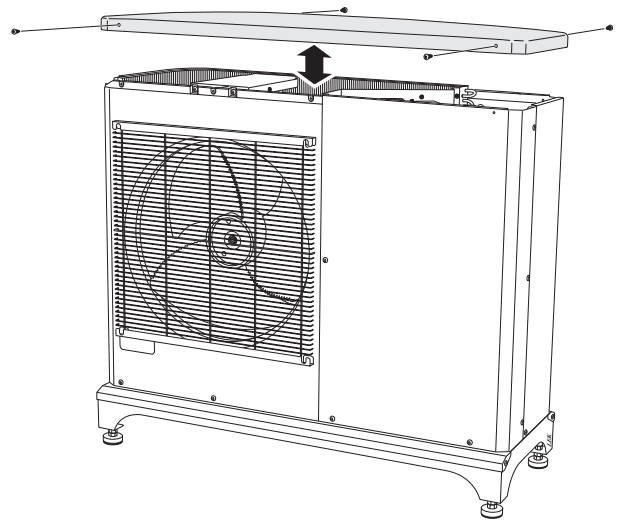

CTC CombiAir 8

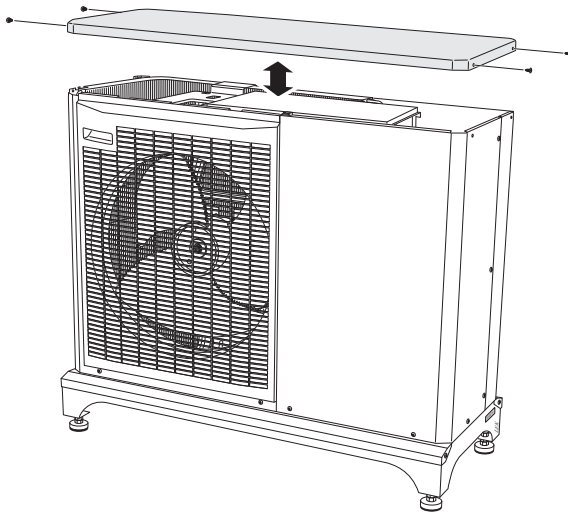

CTC CombiAir 16

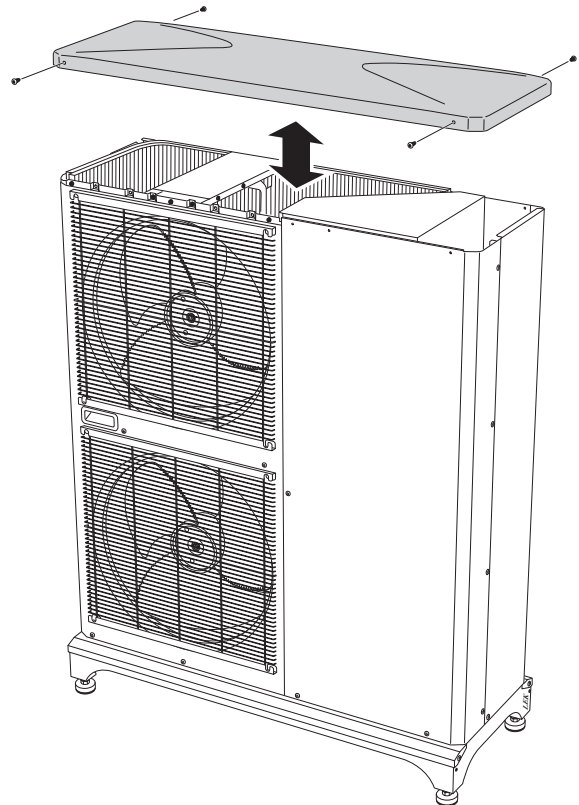

Removing the front panel

CTC CombiAir 6

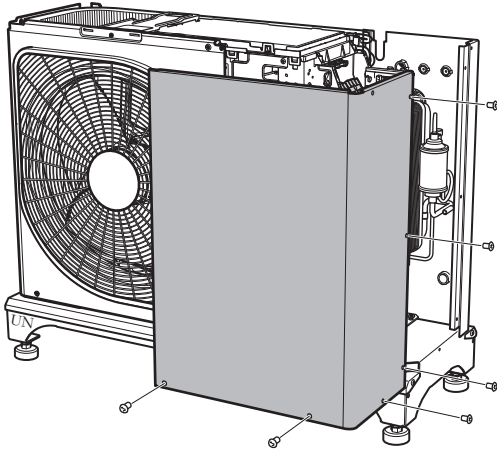

CTC CombiAir 12

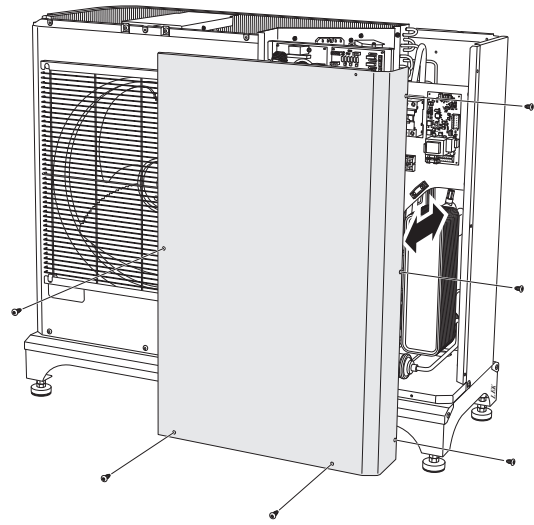

CTC CombiAir 8

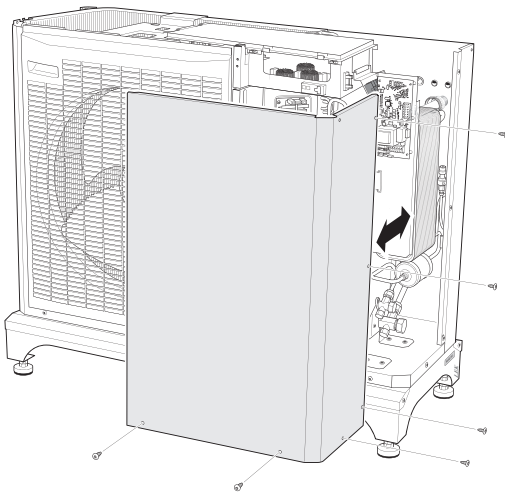

CTC CombiAir 16

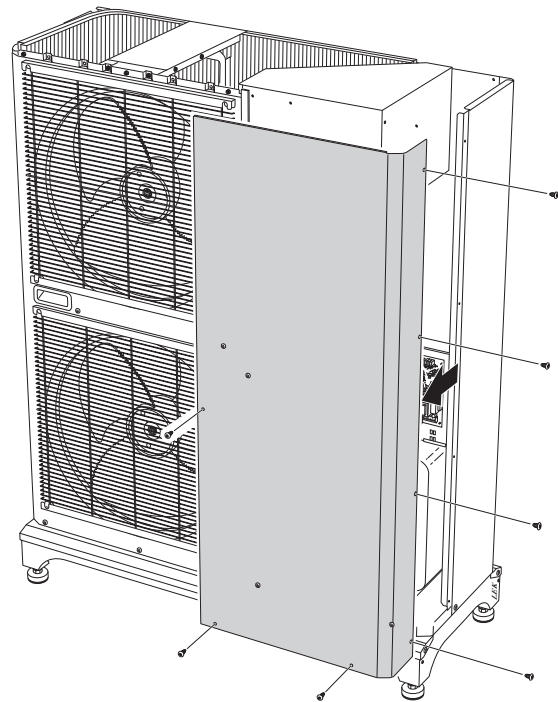

Removing the side panel

CTC CombiAir 12

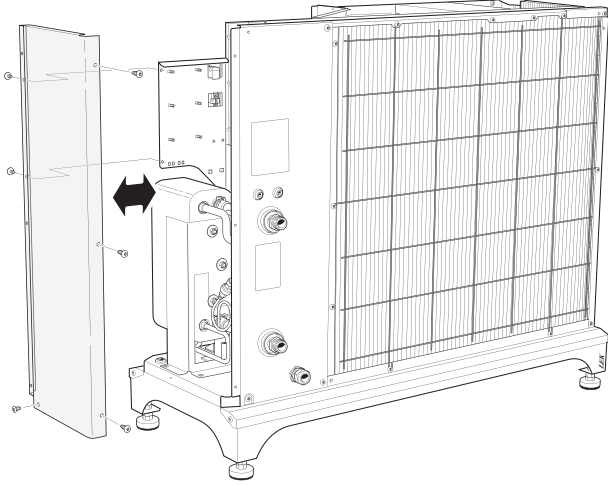

CTC CombiAir 16

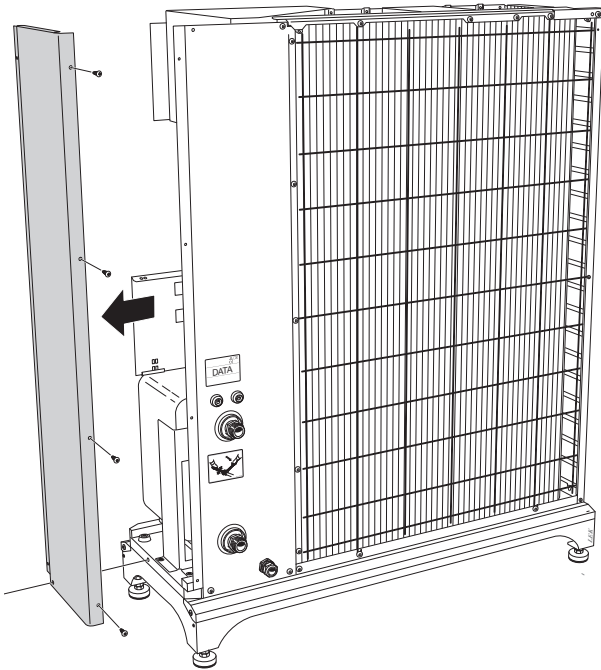

3 The heat pump design

General

CTC CombiAir 6

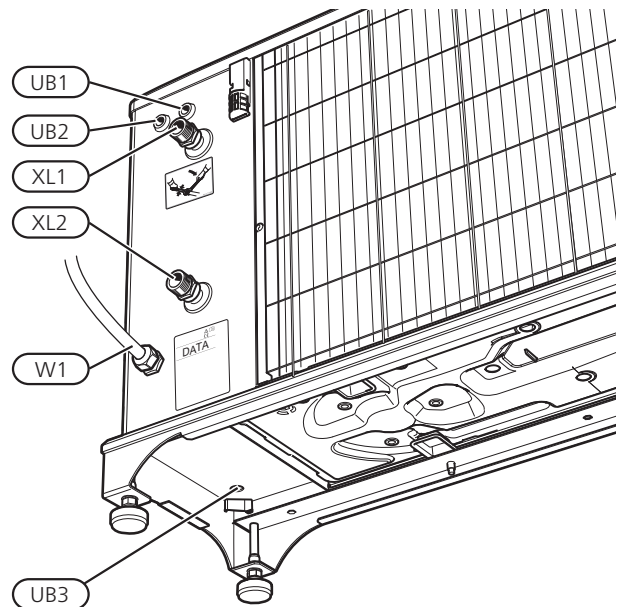
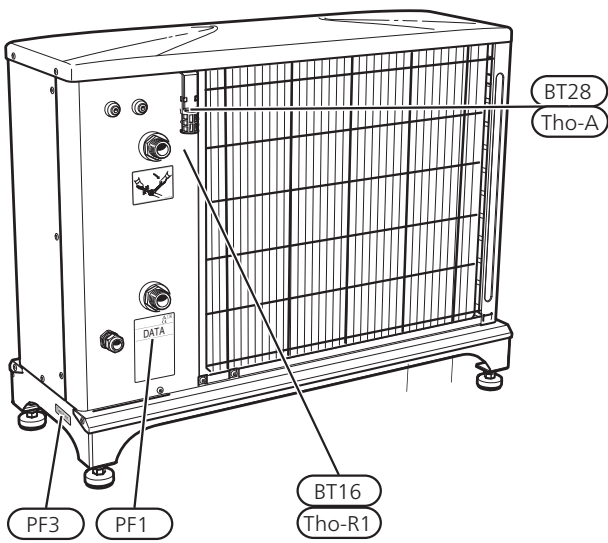
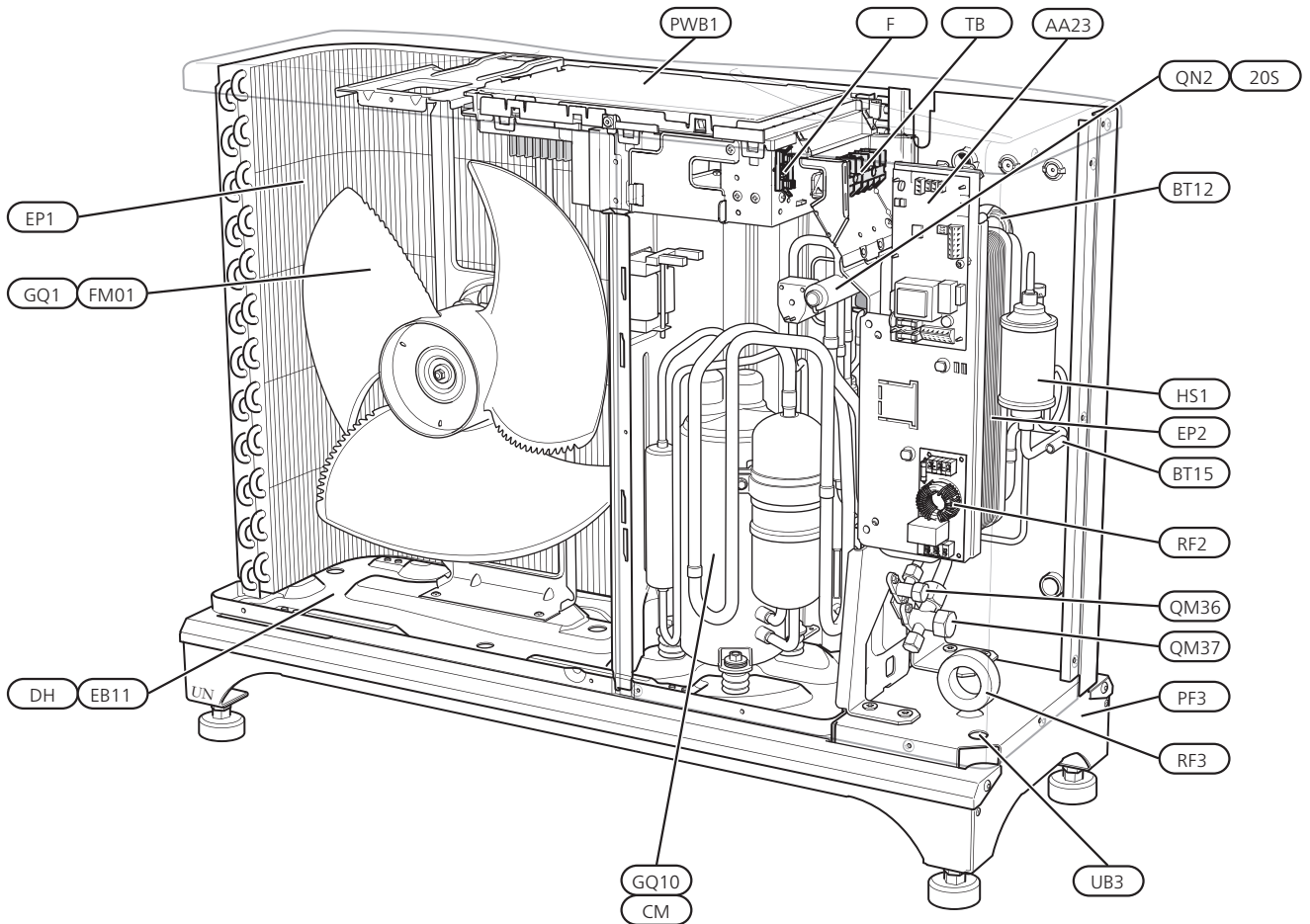

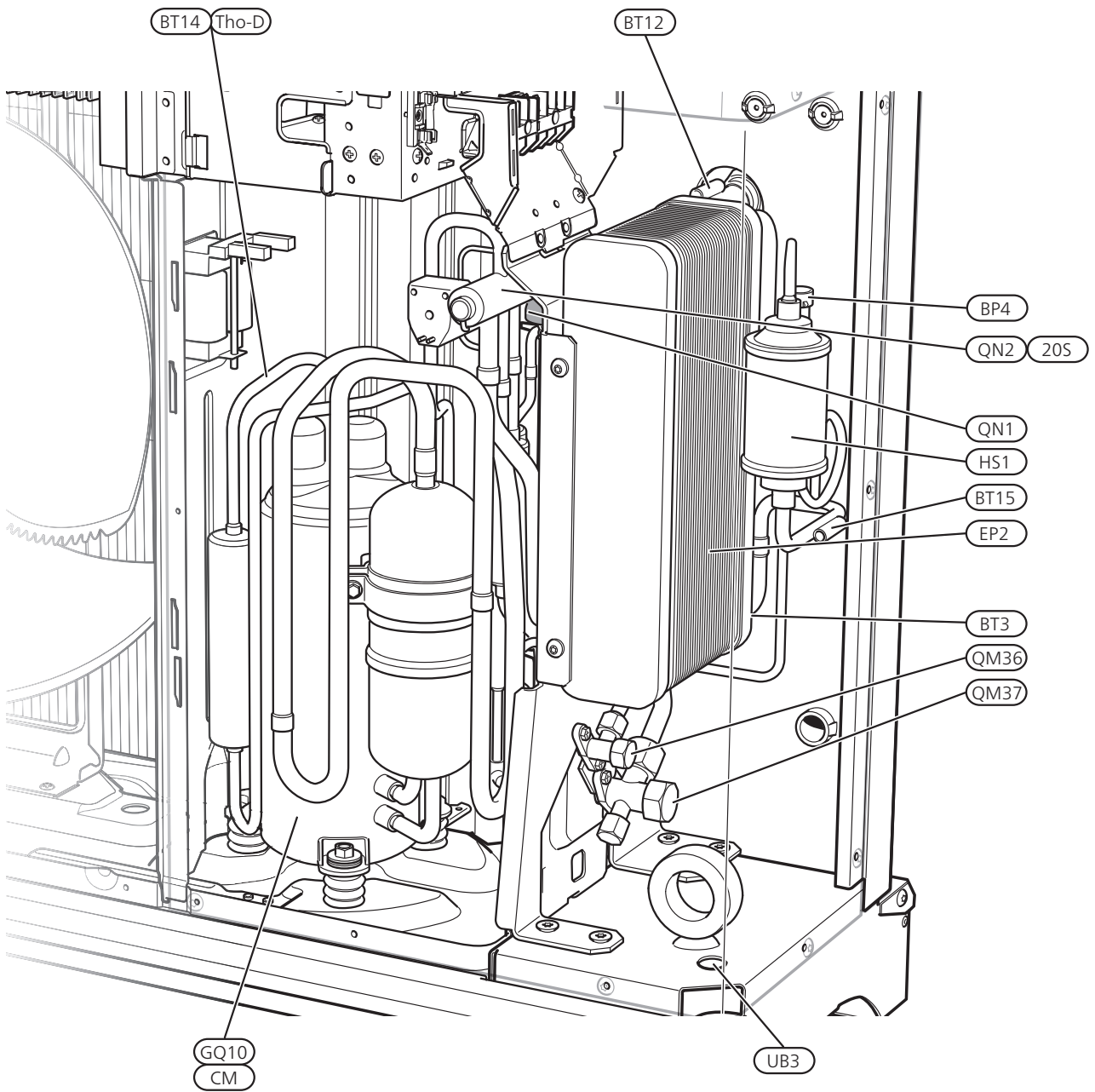

CTC CombiAir 8

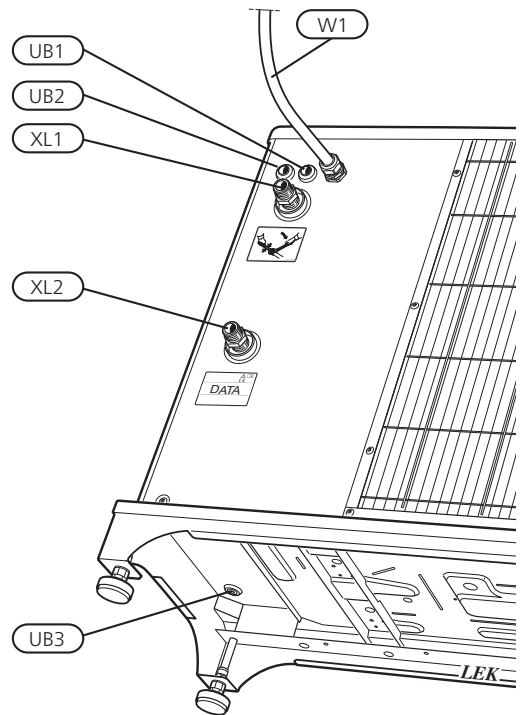
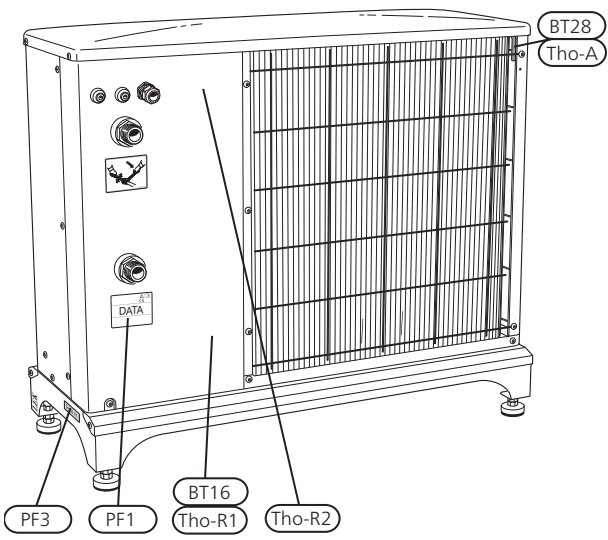
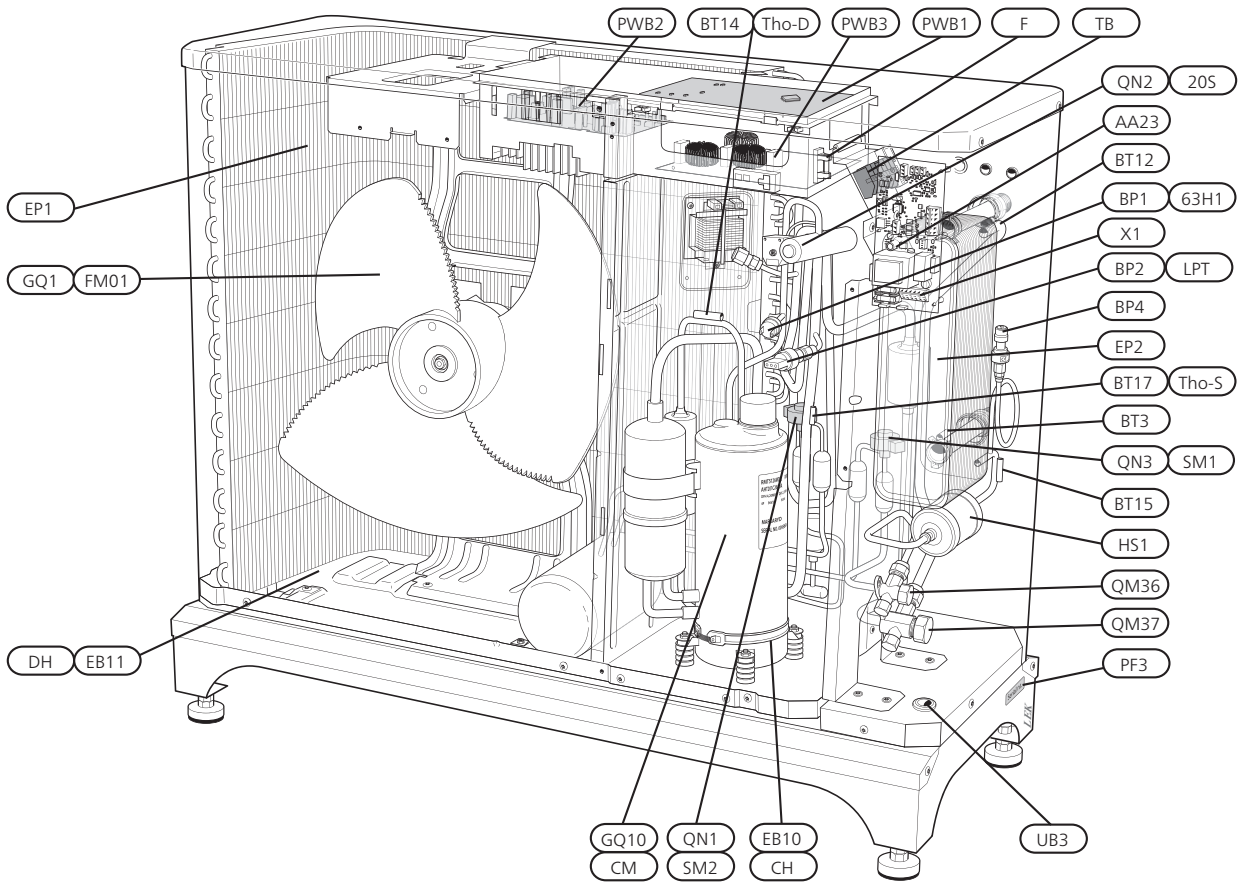

CTC CombiAir 12

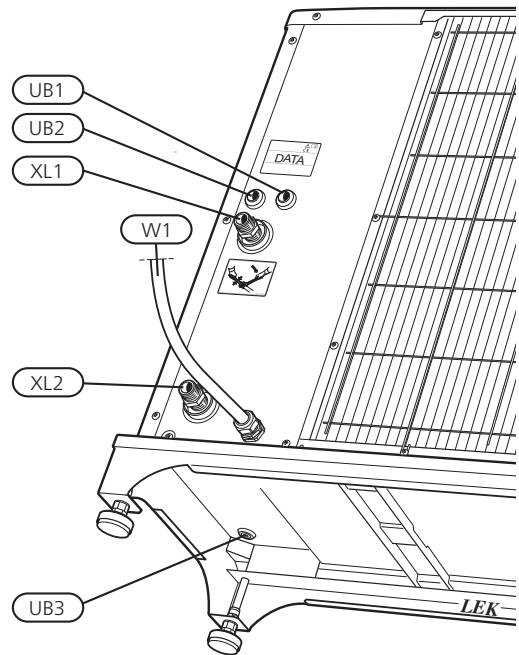
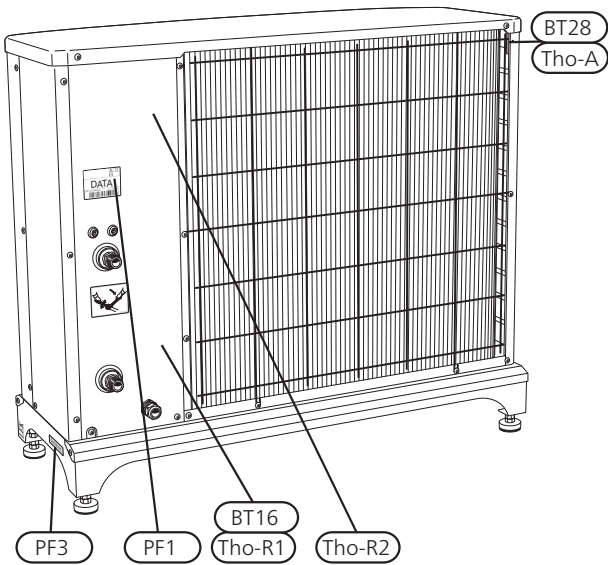
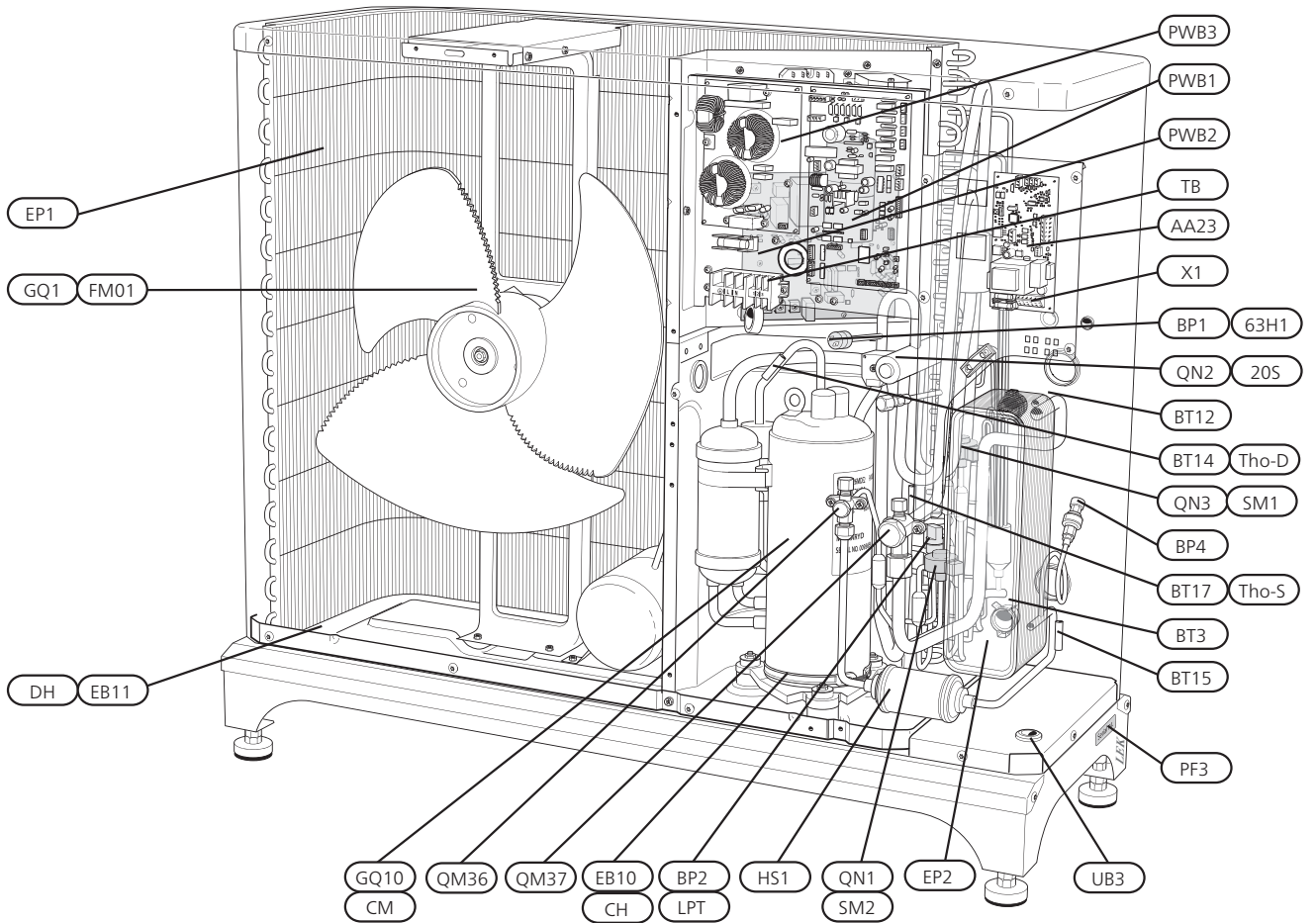

CTC CombiAir 16

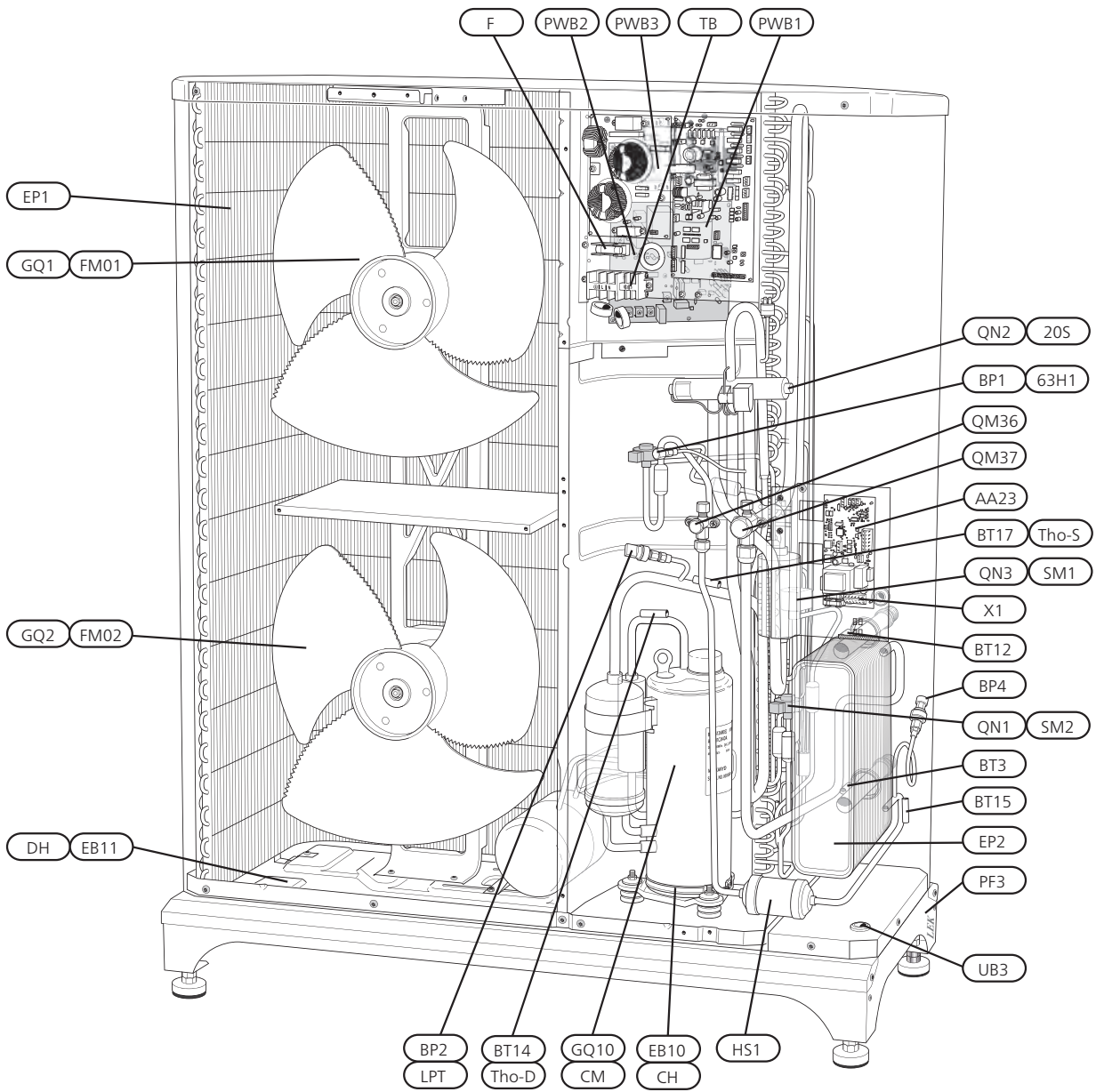

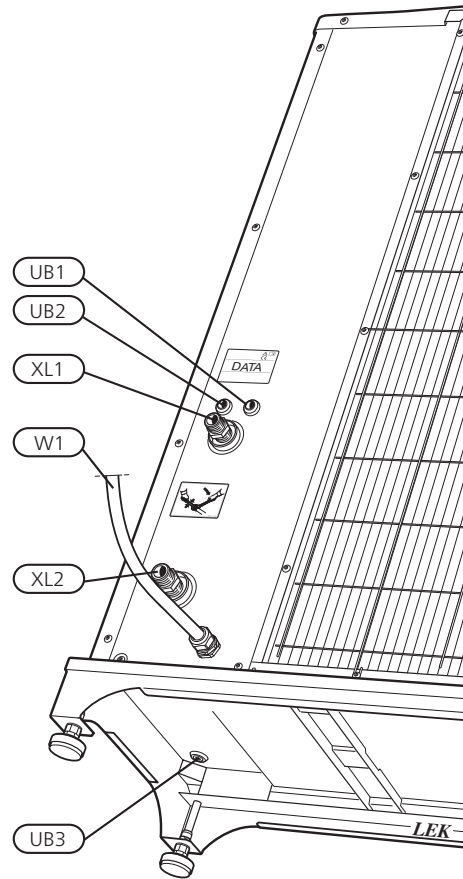
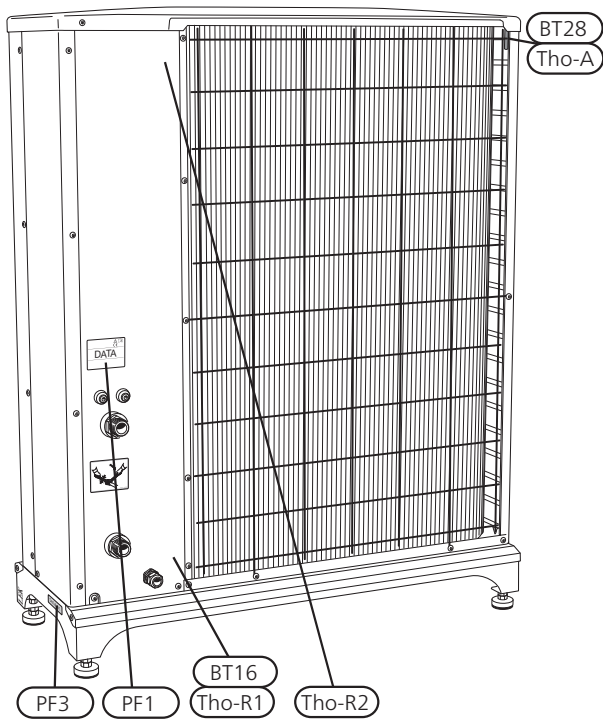

List of components CTC CombiAir

Pipe connections

QM36	Shut-off valve, liquid side
QM37	Shut-off valve, gas side
XL1	Connection, heating medium out from the heat pump, G1" (Ø28 mm)
XL2	Connection, heating medium in to the heat pump, G1" (Ø28 mm)

Sensors etc.

BP1 (63H1)	High pressure pressostat
BT3	Temperature sensor, heating medium return line
BT12	Temperature sensor, condenser supply line
BT14 (Tho-D)	Temperature sensor, hot gas
BT15	Temperature sensor, fluid pipe
BT16 (Tho-R1)	Temperature sensor 1, evaporator
BT17 (Tho-S)	Temperature sensor, suction gas
BT28 (Tho-A)	Temperature sensor, ambient
BP2 (LPT)	Low pressure transmitter
BP4	High pressure sensor
Tho-R2	Temperature sensor 2, evaporator

Electrical components

AA23	Communication board
AA23-F3	Fuse for external heating cable (250 mA), max 45 W.
AA23-S3	DIP switch, addressing of outdoor unit
AA23-X1	Terminal block, KVR
AA23-X4	Terminal block, communication from indoor module
AA23-X100	Communication with TB
EB10 (CH)	Compressor heater
EB11 (DH)	Drip tray heater
F	Main fuse compressor unit
GQ1 (FM01)	Fan
GQ2 (FM02)	Fan
(PWB1)	Control board
(PWB2)	Inverter board
(PWB3)	Filter board
RF2	EMC filter for inverter
RF3	EMC filter for incoming supply
(TB)	Terminal block, incoming supply and communication with board AA23

Cooling components

QN2 (20S)	4-way valve
GQ10 (CM)	Compressor
QN3 (SM1)	Expansion valve, cooling
QN1 (SM2)	Expansion valve, heating
EP1	Evaporator (copper pipe with aluminium flange)
EP2	Condenser
HS1	Drying filter

Miscellaneous

PF1	Type plate
PF3	Serial number
UB1	Cable gland, incoming supply
UB2	Cable grommet, communication
UB3	Cable gland, heating cable (EB14)
W1	Cable, incoming supply

Designations according to standard EN 81346-2.

Designations within brackets according to the supplier's standard.

Electrical connection

CTC CombiAir 6

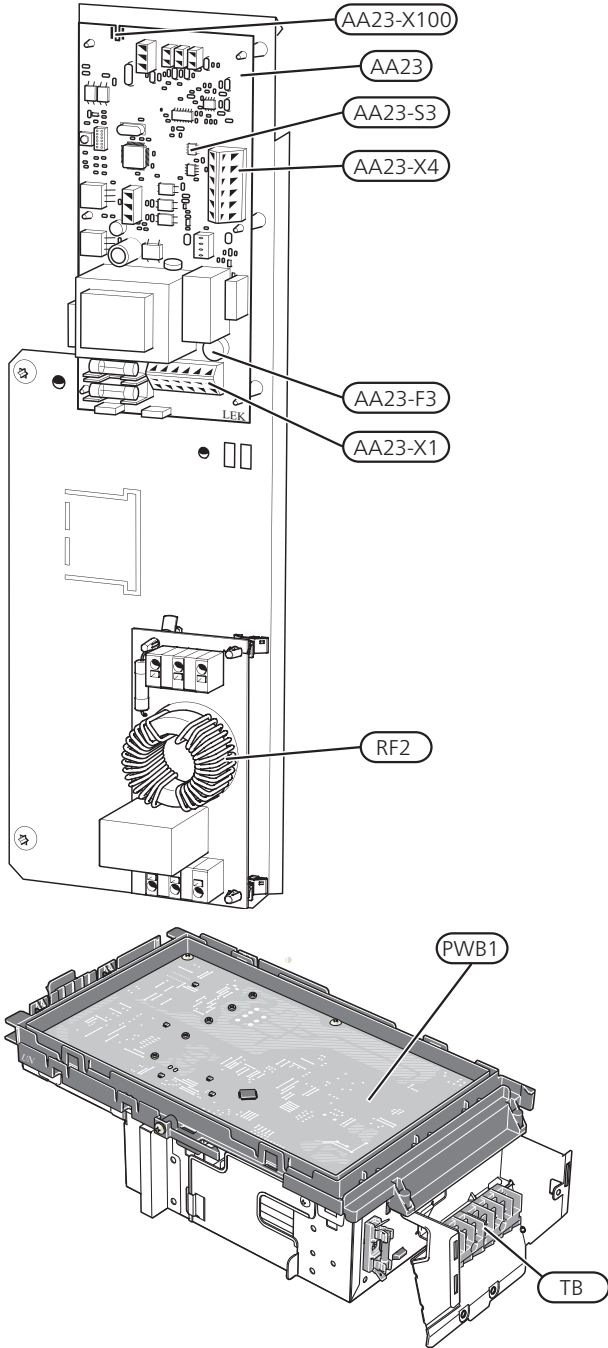

CTC CombiAir 8

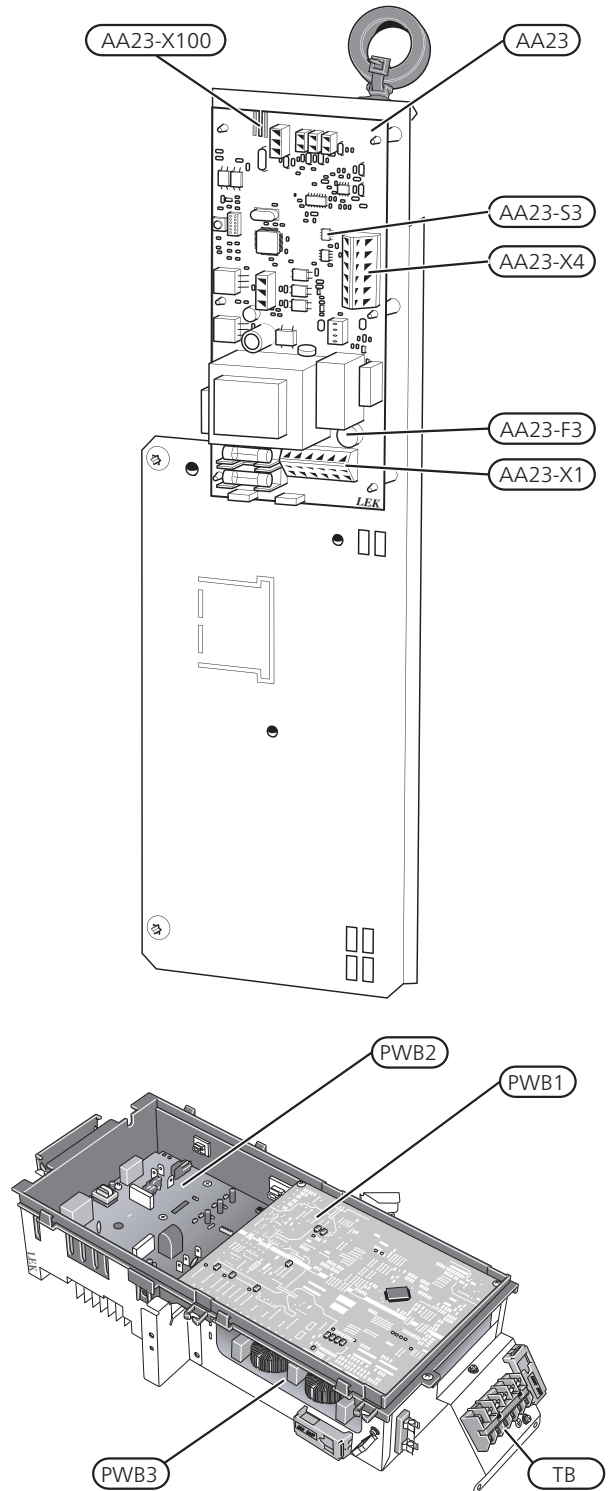

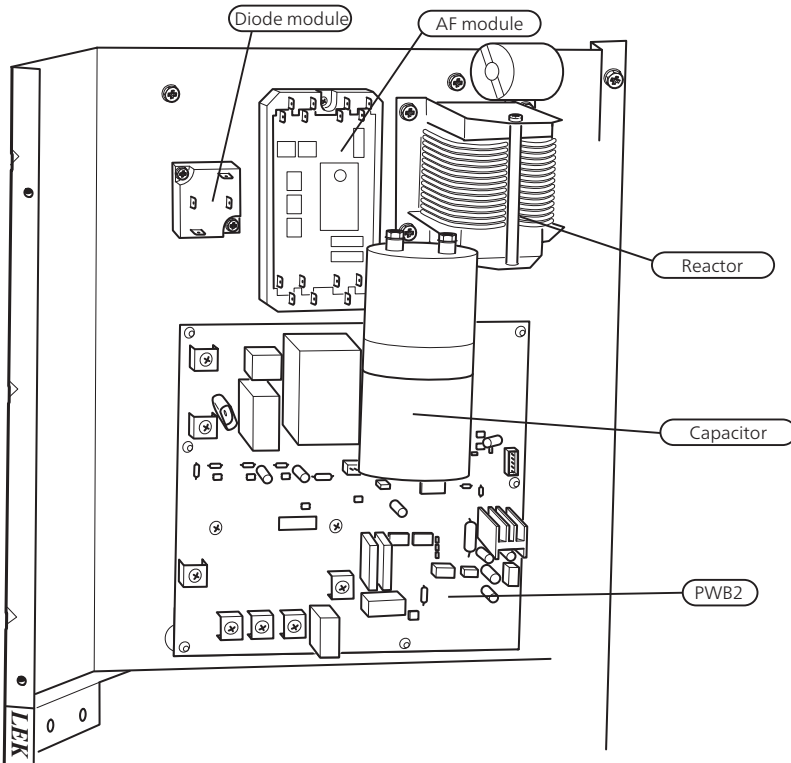
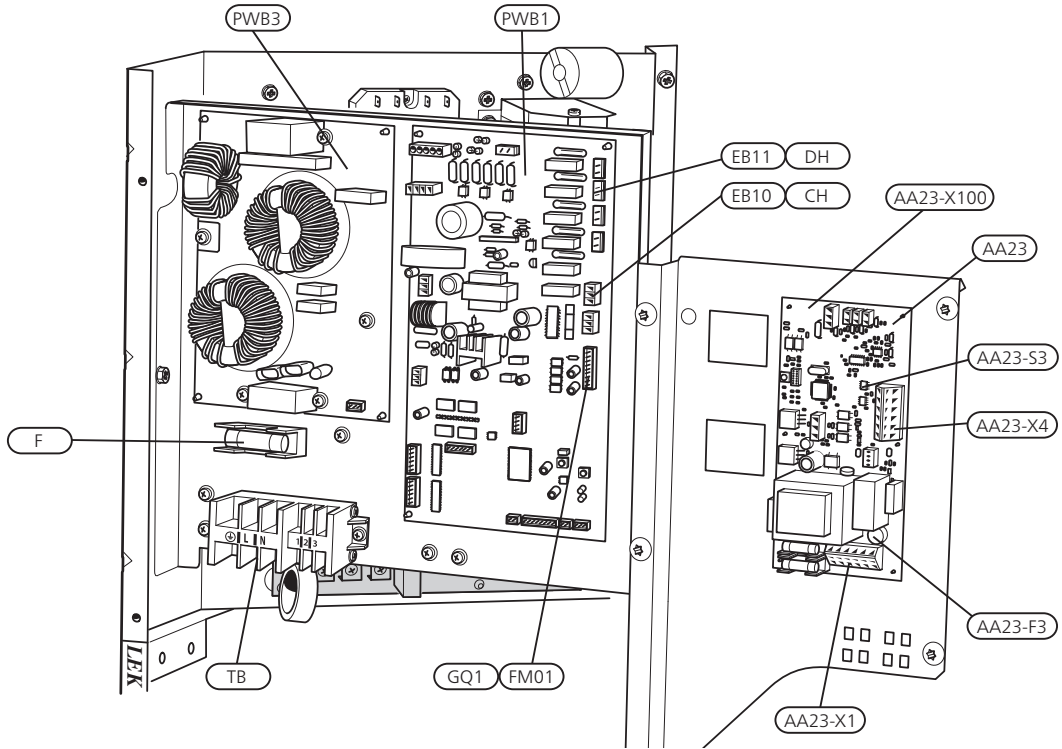

CTC CombiAir 16

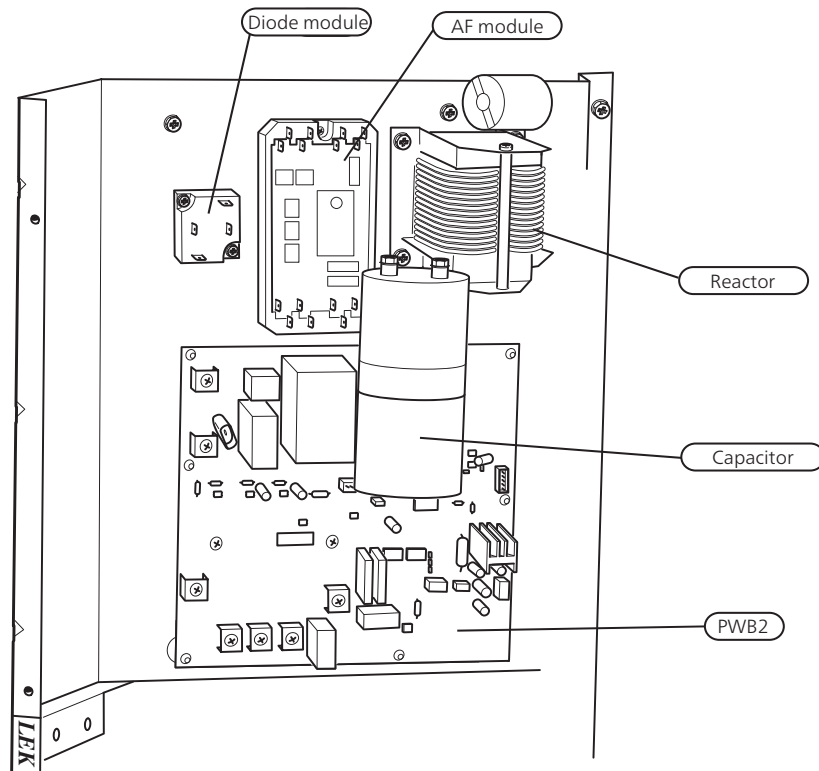
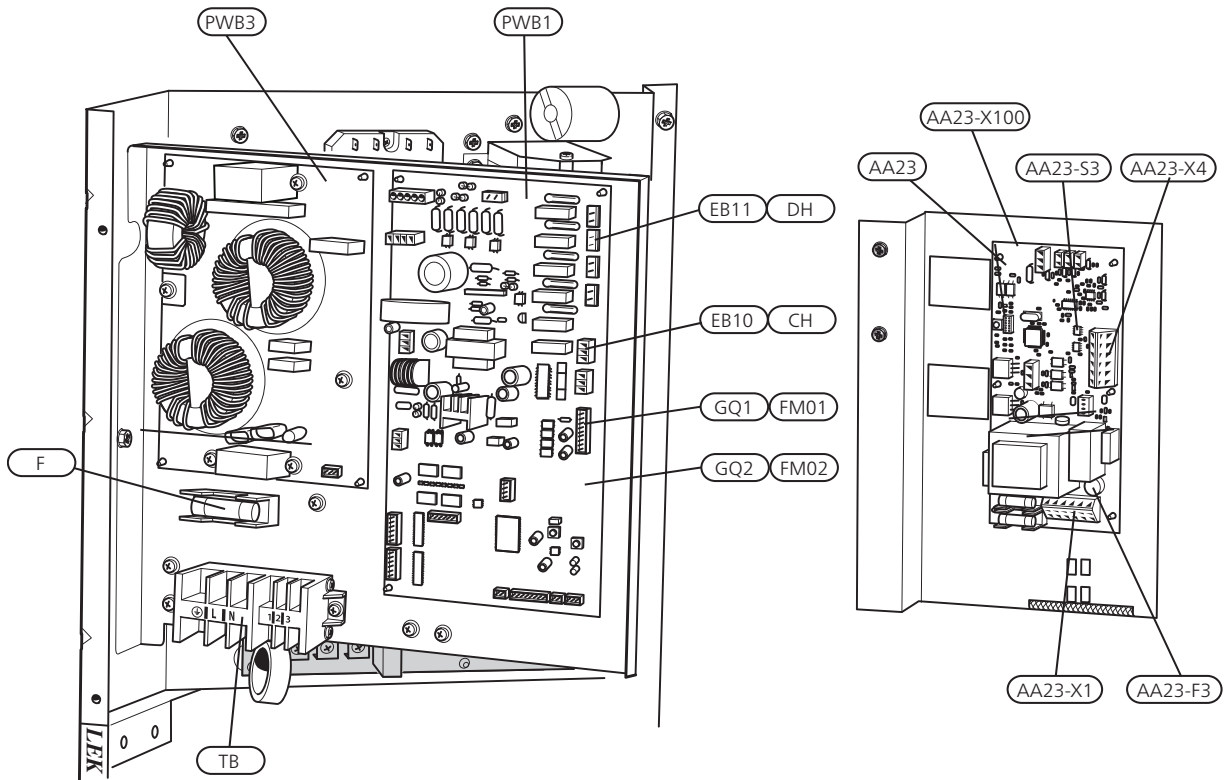

Electrical components

AA23	Communication board
AA23-F3	Fuse for external heating cable (250 mA), max 45 W.
AA23-S3	DIP switch, addressing of outdoor unit
AA23-X1	Terminal block, KVR
AA23-X4	Terminal block, communication from indoor module
AA23-X100	Communication with TB
EB10 (CH)	Compressor heater
EB11 (DH)	Drip tray heater
F	Main fuse compressor unit
GQ1 (FM01)	Fan
GQ2 (FM02)	Fan
(PWB1)	Control board
(PWB2)	Inverter board
(PWB3)	Filter board
RF2	EMC filter for inverter
RF3	EMC filter for incoming supply
(TB)	Terminal block, incoming supply and communication with board AA23

Designations according to standard EN 81346-2.

Designations within brackets according to the supplier's standard.

Sensor data

Tho-D

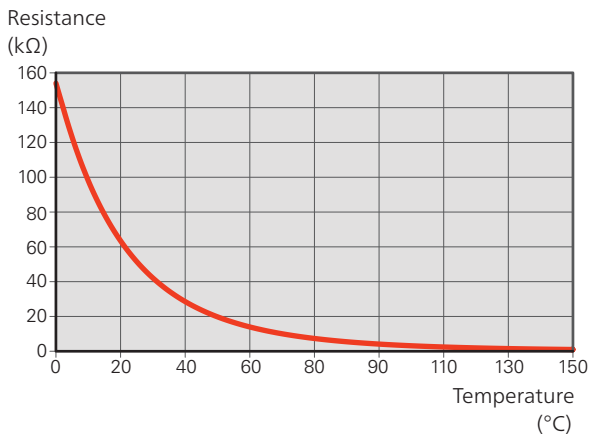

Tho-A, R

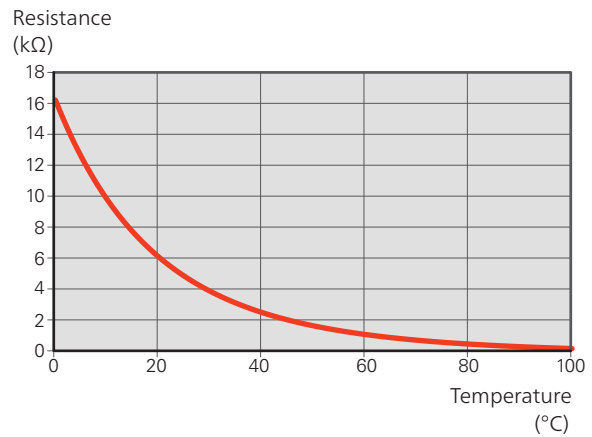

Tho-D

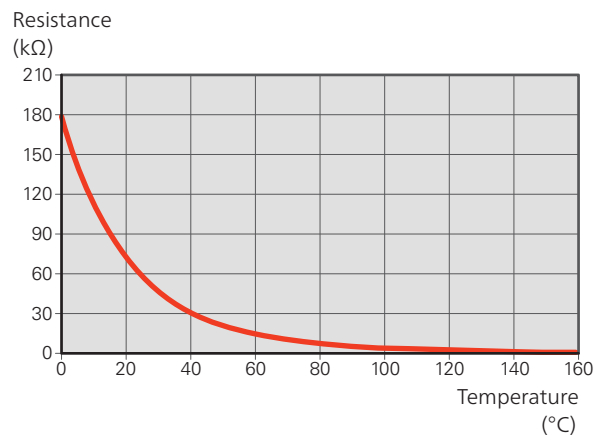

Tho-S, Tho-R1, Tho-R2

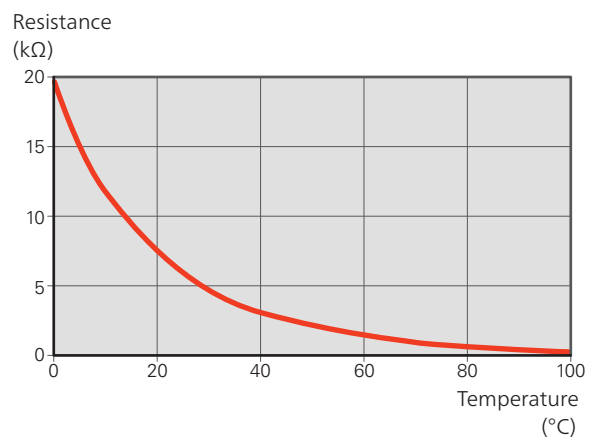

Tho-A (BT28)

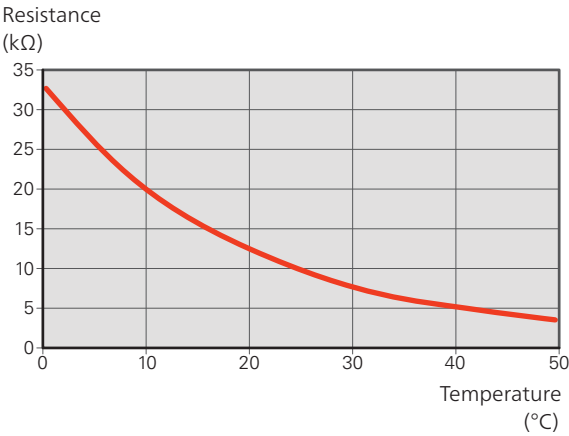

4 Pipe connections

General

Pipe installation must be carried out in accordance with current norms and directives.

The pipe dimension should not be less than the recommended pipe diameter according to the table. However, each system must be dimensioned individually to manage the recommended system flows.

Minimum system flows

The installation must be dimensioned at least to manage the minimum defrosting flow at 100% pump operation, see table.

Air/water heat pump	Minimum flow during defrosting (100% pump speed (l/s))	Minimum recommended pipe dimension (DN)	Minimum recommended pipe dimension (mm)
CTC Combi-Air 6	0.19	20	22
CTC Combi-Air 8	0.19	20	22
CTC Combi-Air 12	0.29	20	22
CTC Combi-Air 16	0.39	25	28



NOTE

An undersized system can result in damage to the machine and lead to malfunctions.

CTC CombiAir can only operate up to a return temperature of about 55 °C and an outgoing temperature of about 58 °C from the heat pump.

CTC CombiAir is not equipped with external shut off valves on the water side; these must be installed to facilitate any future servicing. The return temperature is limited by the return line sensor.

Water volumes

When docking with CTC CombiAir, free flow in the climate system is recommended for correct heat transfer. This can be achieved through the use of a bypass valve. If free flow cannot be ensured, it is recommended that a buffer tank be installed.

Following water volumes are recommended

CTC CombiAir	6	8	12	16
Minimum volume, climate system during heating/cooling	20 l	50 l	80 l	150 l
Minimum volume, climate system during under floor cooling	50 l	80 l	100 l	150 l



NOTE

The pipe work must be flushed before the heat pump is connected, so that any contaminants do not damage the components.

Pipe coupling heating medium circuit

- CTC CombiAir can be connected to the heating system according to one of the system solutions that can be downloaded from the website ctc.se.
- The heat pump must be vented by the upper connection (XL1) using the venting nipple on the enclosed flexible hose.
- Install the enclosed particle filter before the inlet, i.e. the lower connection (XL2) on CTC CombiAir.
- All outdoor pipes must be thermally insulated with at least 19 mm thick pipe insulation.
- Install shutoff and drain valves so that CTC CombiAir can be emptied in the event of prolonged power failures.
- The supplied flexible hoses act as vibration dampers. The flexible pipes are fitted so an elbow is created, thus acting as vibration damping.

Charge pump

The charge pump (not included in the product) is powered and controlled from the indoor module/control module. It has a built-in anti-freezing function and must therefore not be switched off when there is a risk of freezing.

At temperatures below +2 °C the charge pump runs periodically, to prevent the water from freezing in the charge circuit. The function also protects against excess temperatures in the charge circuit.

Pressure drop diagram

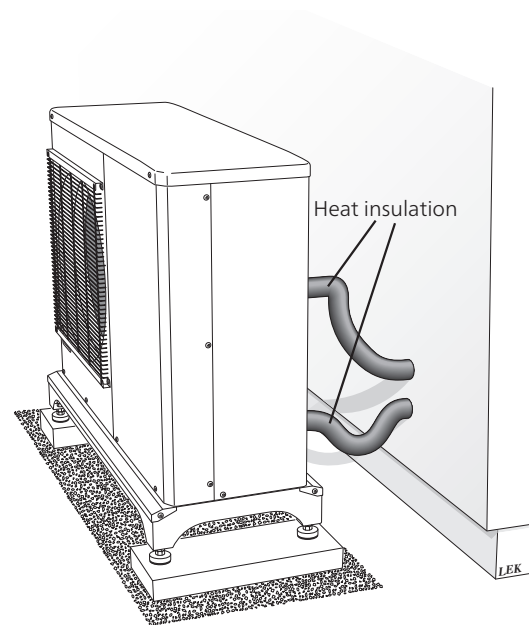
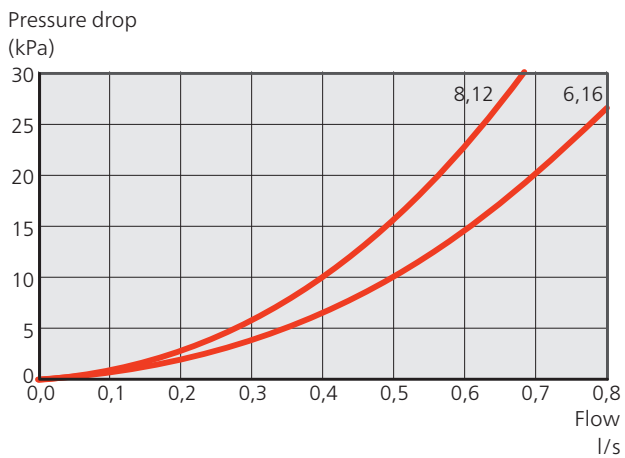

Pipe connections flex hose

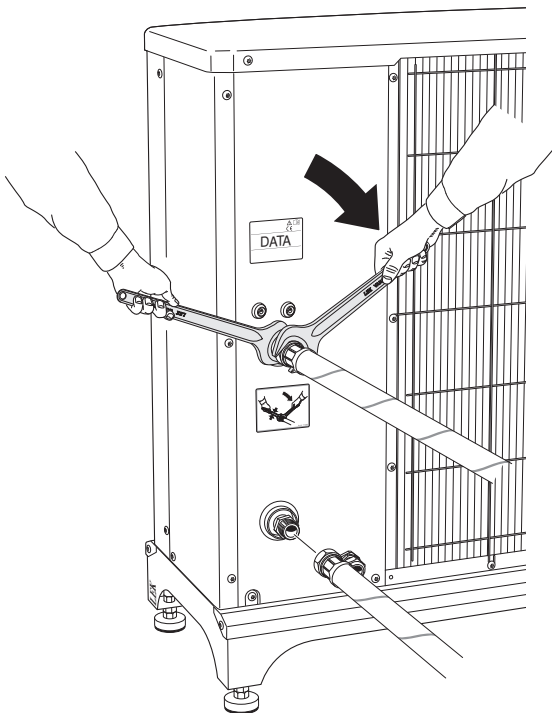

Docking alternatives

The safety equipment must be installed in accordance with current regulations for all docking options.

For information about docking options, see the manual for the controlling product.

Connecting accessories

Instructions for connecting accessories can be found in the installation instructions provided for each accessory. See section Accessories for a list of the accessories that can be used with CTC CombiAir .

5 Electrical connections

General

- The heat pump must not be connected without the permission of the electricity supplier and must be connected under the supervision of a qualified electrician.
- If a miniature circuit-breaker is used, this must have motor characteristic "C" (compressor operation). For MCB size, see "Technical specifications".
- CTC CombiAir does not include an omnipolar circuit breaker on the incoming power supply. The heat pump's supply cable (W1) must therefore be connected to a circuit breaker with a breaking gap of at least 3 mm. If the building is equipped with a residual current device, the heat pump should be equipped with a separate one. The residual current device should have a nominal tripping current of no more than 30 mA. Incoming supply must be 230 V 50Hz via electrical distribution units with fuses.
- If an insulation test is to be carried out in the building, disconnect the heat pump.
- Communication cable (W2) is inserted from the rear side through UB2.
- Connect communication cable (W2) from terminal block (AA23-X4) to the indoor module.



NOTE

Electrical installation and any servicing must be carried out under the supervision of a qualified electrician. Disconnect the current with the circuit breaker before carrying out any servicing. Electrical installation and wiring must be carried out in accordance with the national stipulations in force.



NOTE

Check the connections, main voltage and phase voltage before starting the machine to prevent damage to the air/water heat pump's electronics.



NOTE

The live external control must be taken into consideration when connecting.



NOTE

If the supply cable is damaged, only CTC, its service representative or similar authorised person may replace it to prevent any danger and damage.

CTC CombiAir 6

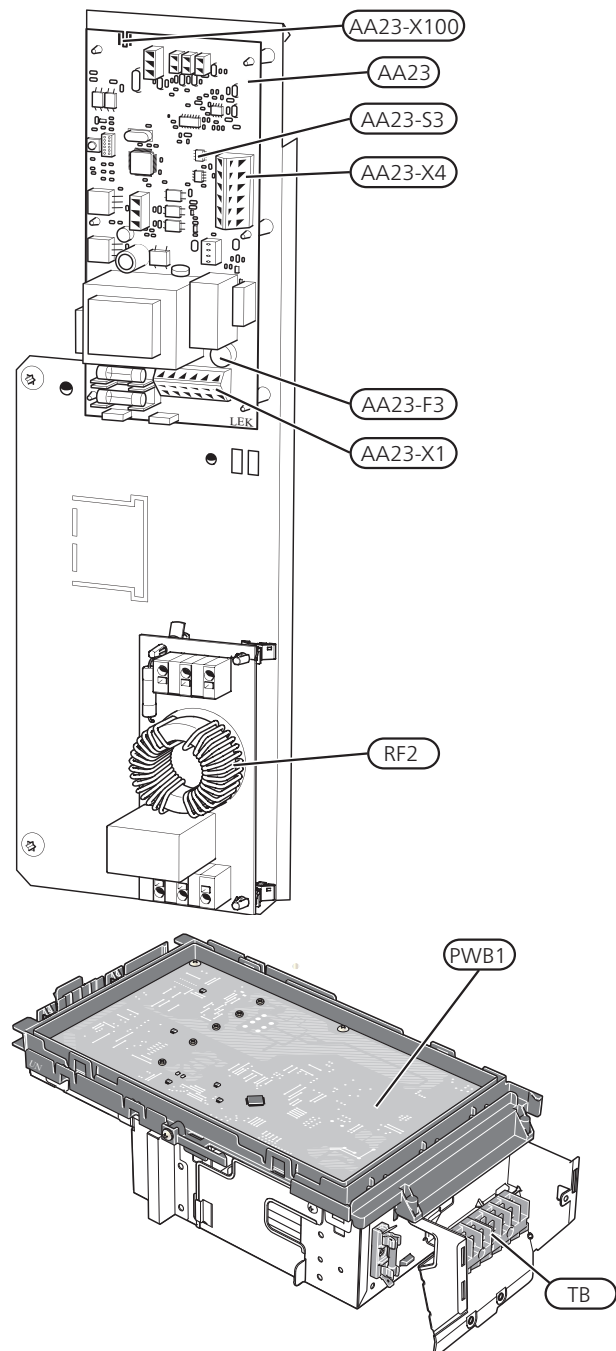

CTC CombiAir 8

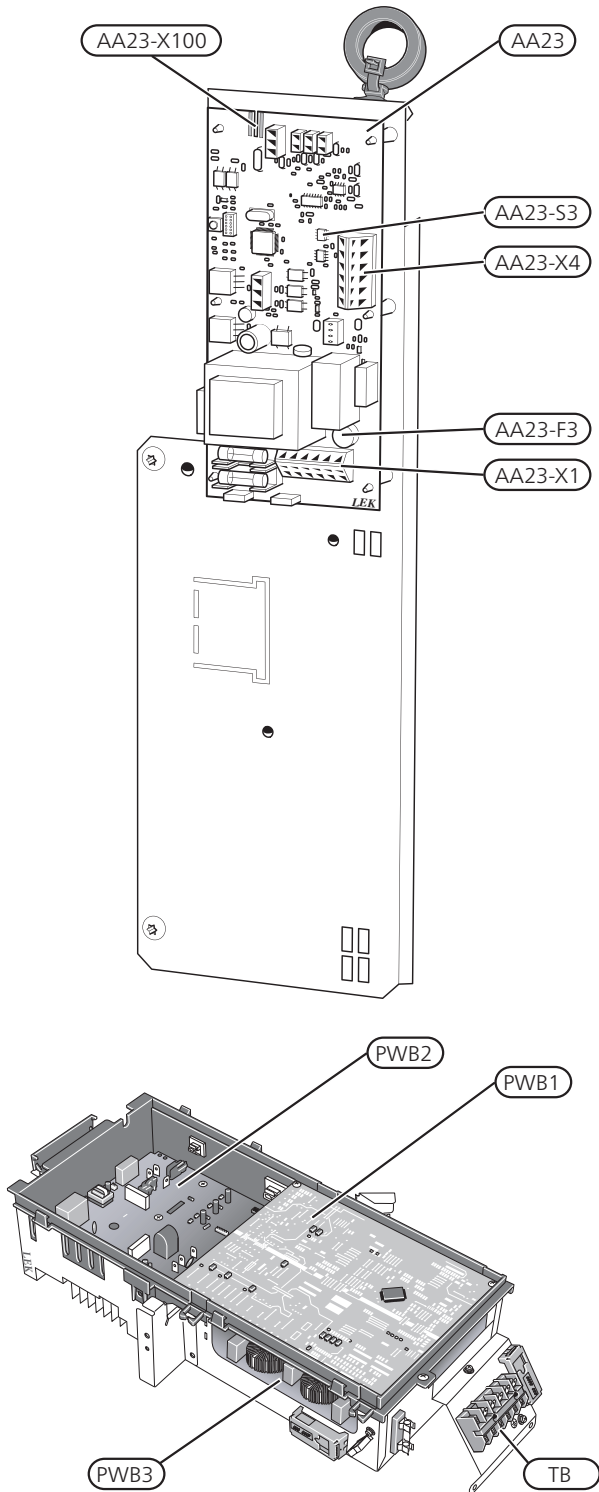

CTC CombiAir 12

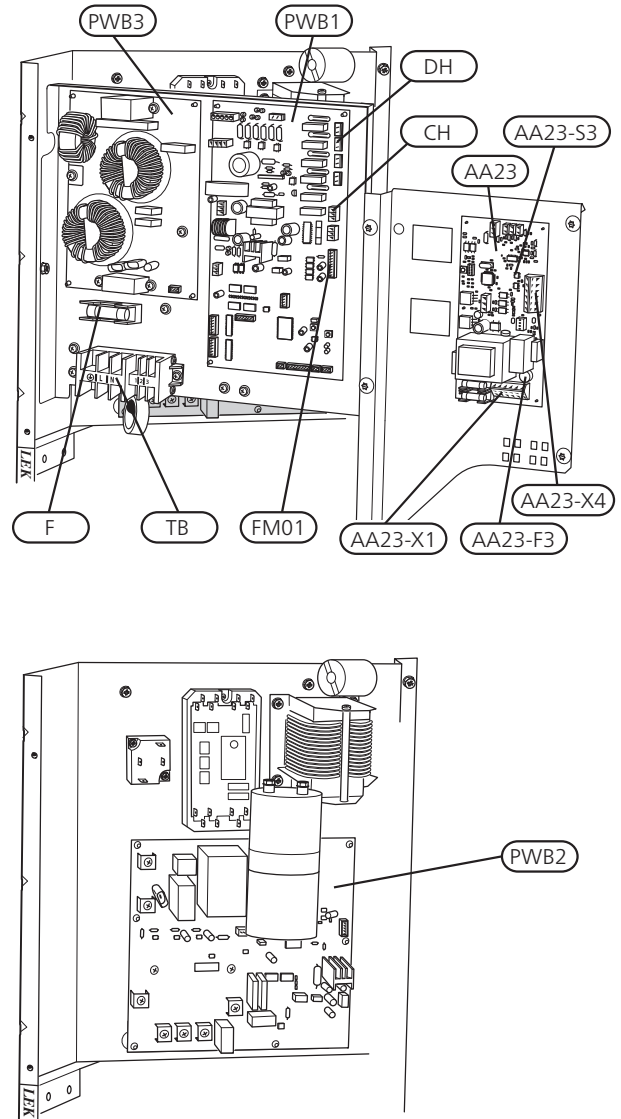

CTC CombiAir 16

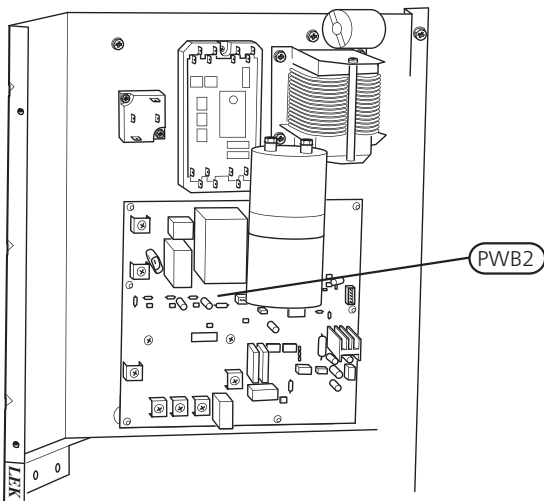
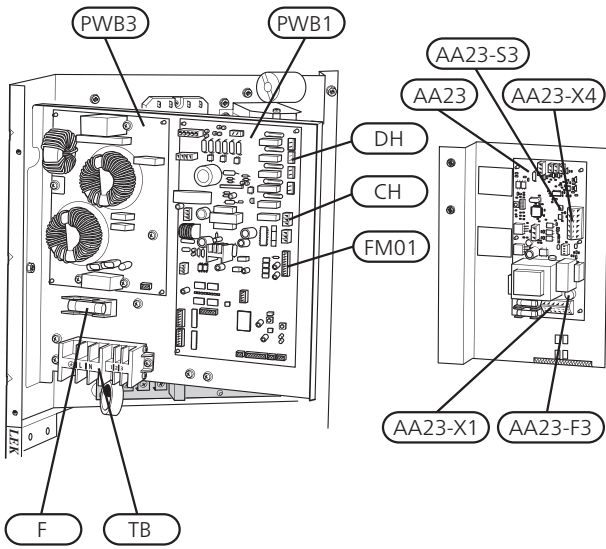

Connections

Power connection

CTC CombiAir 6

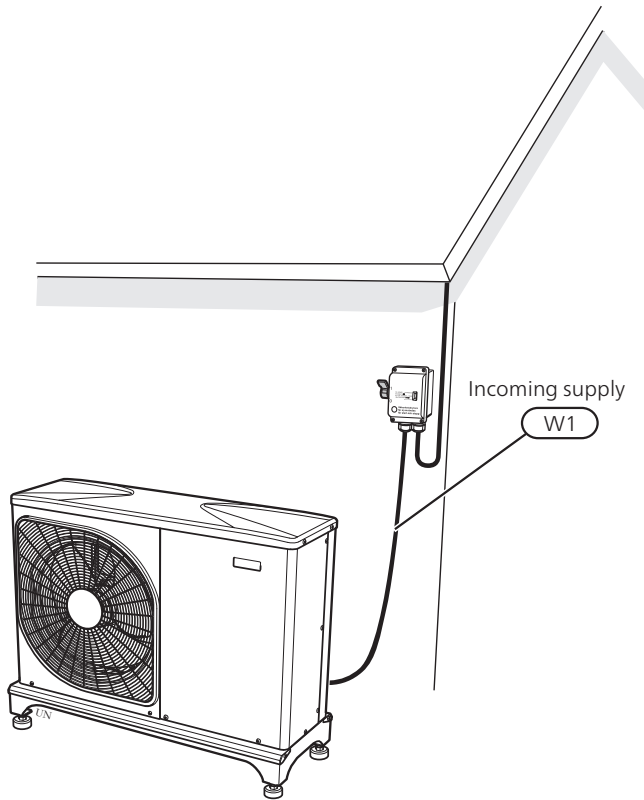

NOTE

To prevent interference, unshielded communication and/or sensor to external connections cables must not be laid closer than 20 cm to high voltage cables when cable routing.

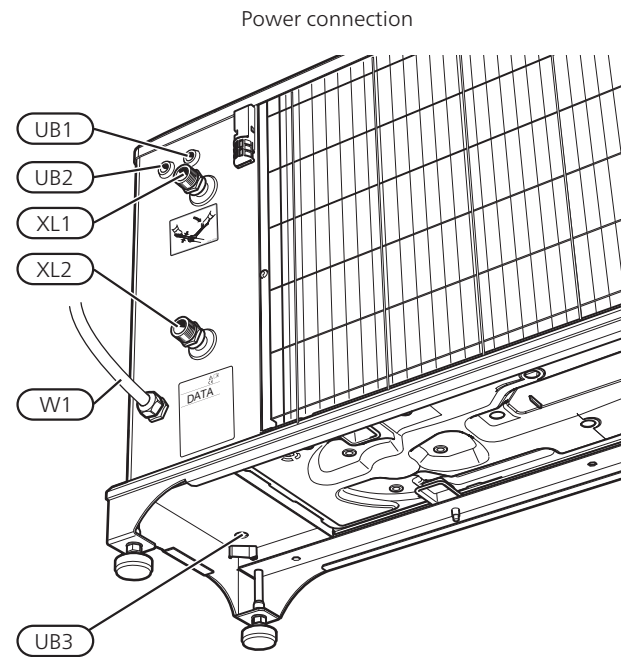

CTC CombiAir 8

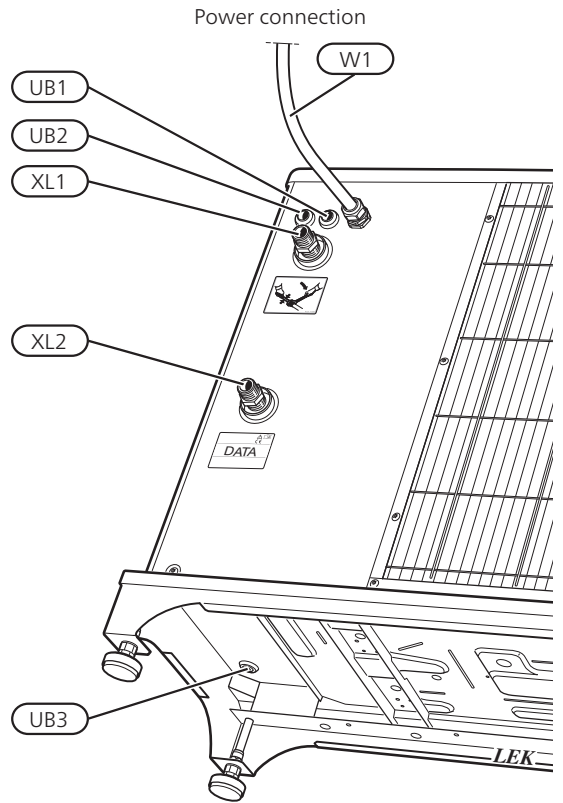
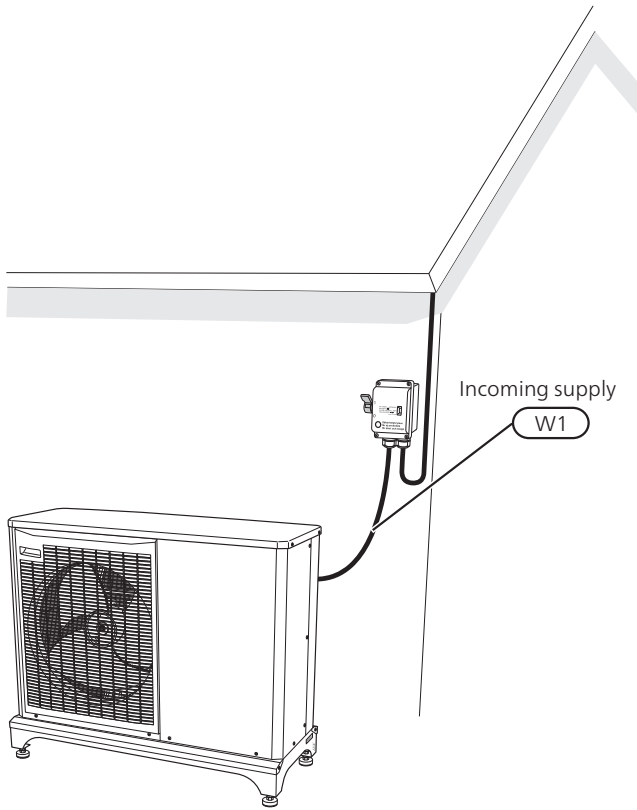

CTC CombiAir 12

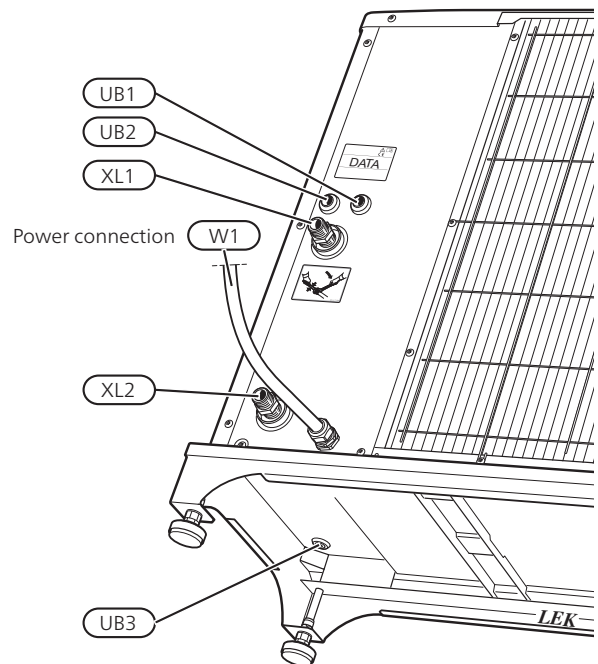
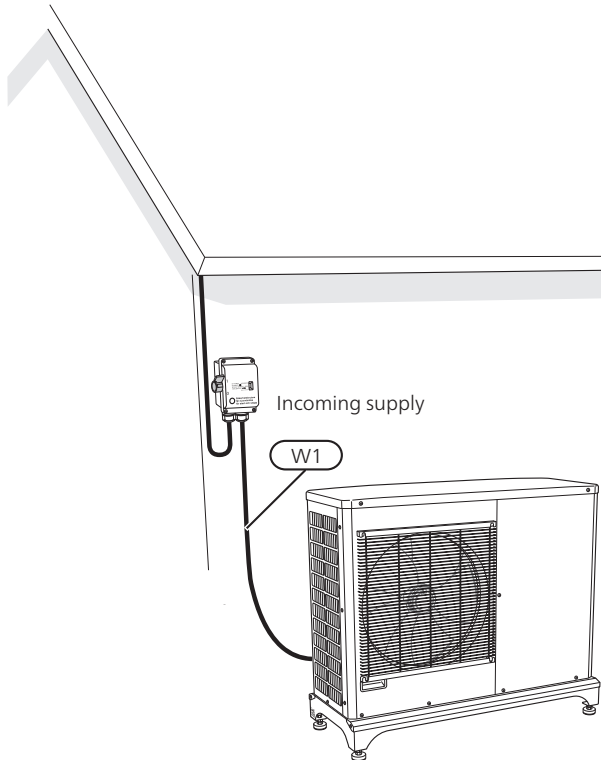

CTC CombiAir 16

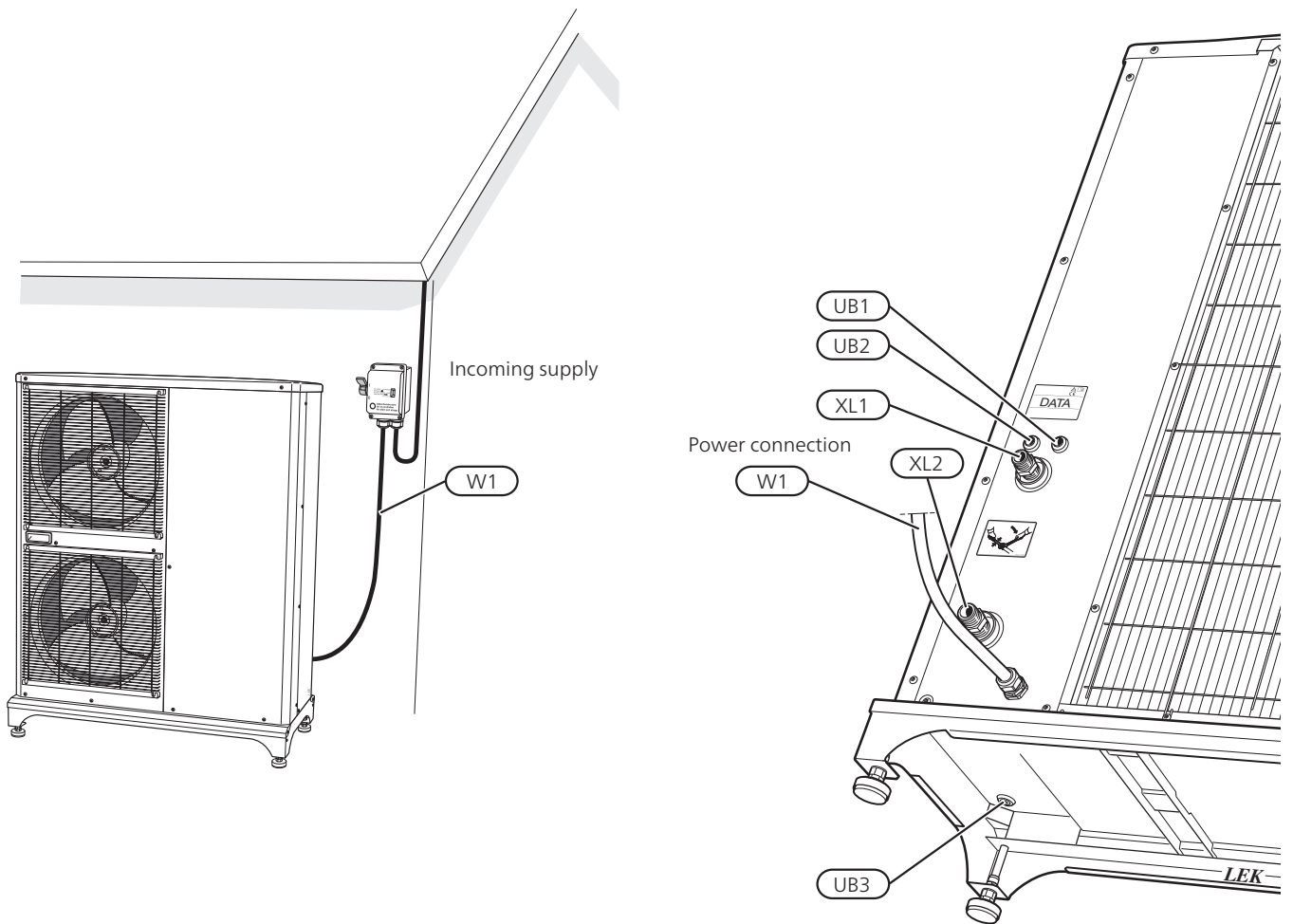

Incoming supply cable (W1) is enclosed and connected to terminal block X1 at the factory. Outside the heat pump there is approx. 1.8 m of cable available.

Connect communication cable (W2) (provided by installer) to terminal block AA23-X4 and secure with two cable ties, see image.

For connection of accessory KVR, heating cable (EB14) is connected via cable grommet UB3, see External heating cable KVR (Accessory) on page 37.

List of components

UB1	Cable grommet, cascade connection
UB2	Cable grommet, communication
UB3	Cable grommet, heating cable (EB14)
W1	Cable, incoming supply

CTC CombiAir 6

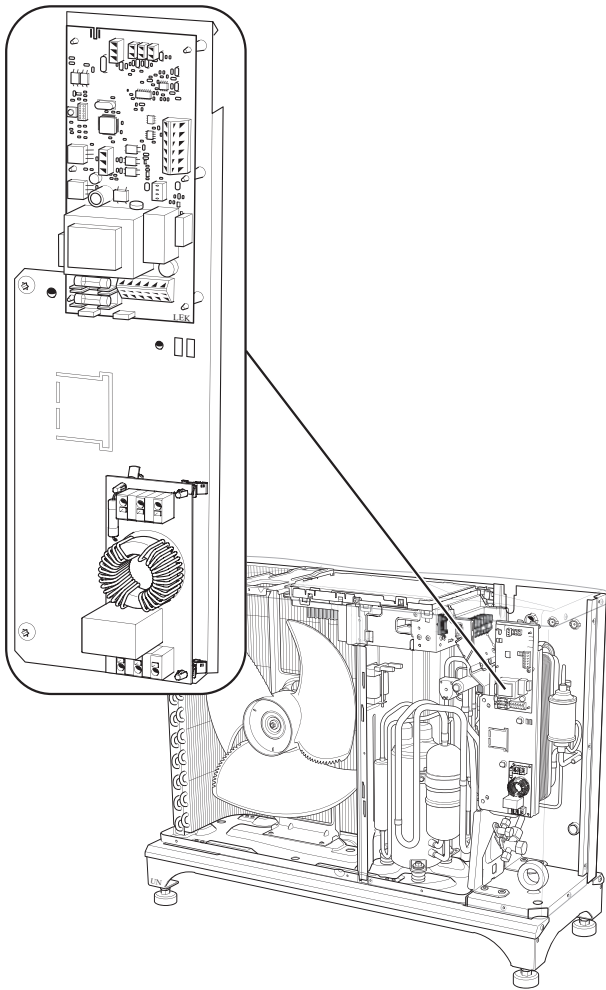

CTC CombiAir 8

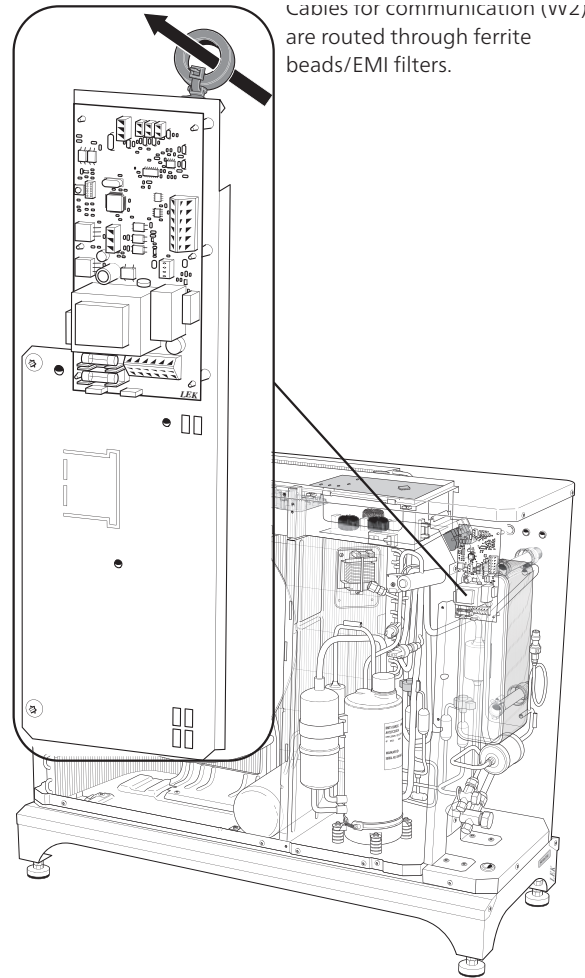

CTC CombiAir 12

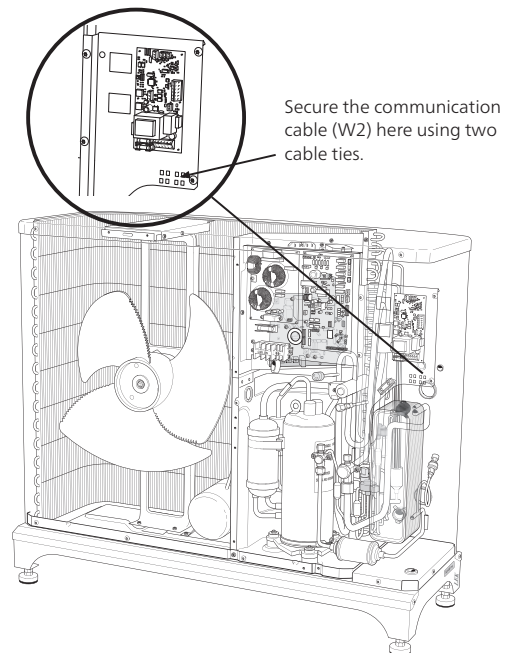

CTC CombiAir 16

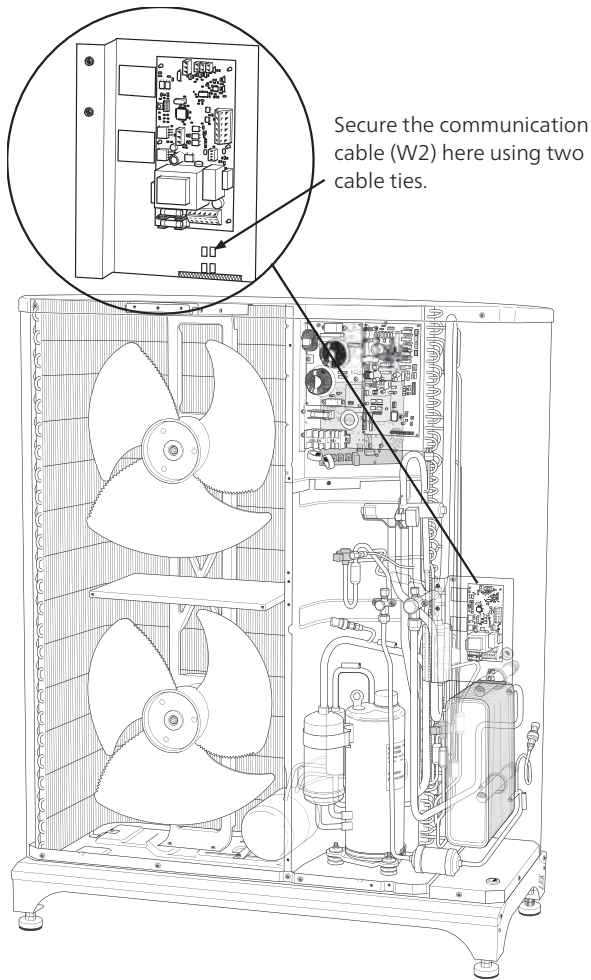

External heating cable KVR (Accessory)

CTC CombiAir is equipped with a plinth for external heating cable (EB14 not supplied). The connection is fused with 250 mA (F3 on the communication board AA23). If another cable is to be used, the fuse must be replaced with a suitable one (see table).



NOTE

Self regulating heating cables must not be connected.

Length, heating cable (m)	P_{tot} (W)	Fuse (F3)	Part No.
1	15	T100mA/250V	718 085
3	45	T250mA/250V	518 900*
6	90	T500mA/250V	718 086

*Fitted at the factory.

Connect external heating cable (EB14) to terminal block X1:4–6 according to following image:

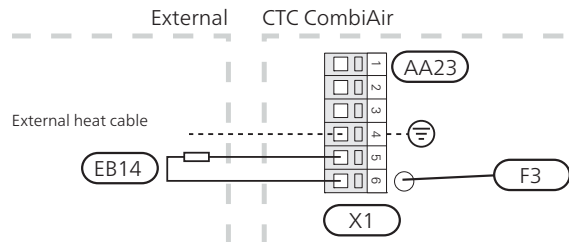

NOTE

The pipe must be able to withstand the heat from the heating cable.

To ensure this function, the accessory KVR should be used.

Cable routing

The following images show recommended cable routing from the electrical connection to the condensation pipe. Route the heating cable (EB14) through the gland on the underside and secure with two cable ties at the electrical connection. The transition between the electrical cable and the heating cable must occur after the gland to the condensation pipe.

CTC CombiAir 6

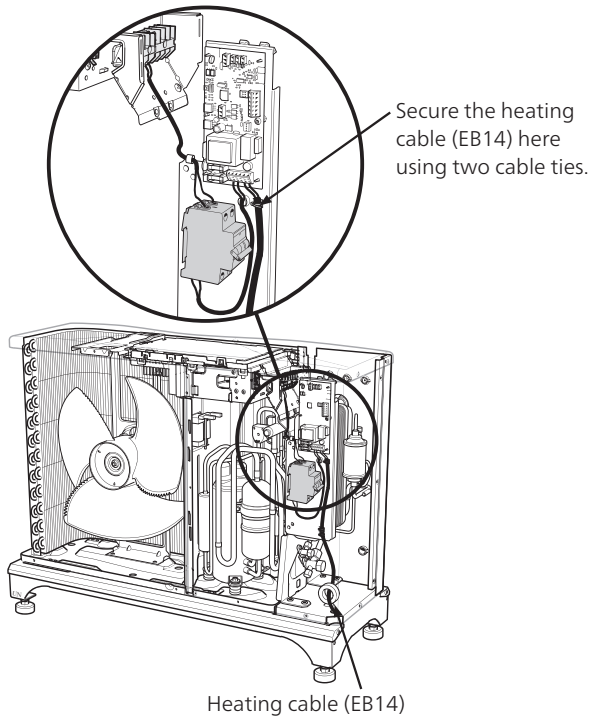

CTC CombiAir 8

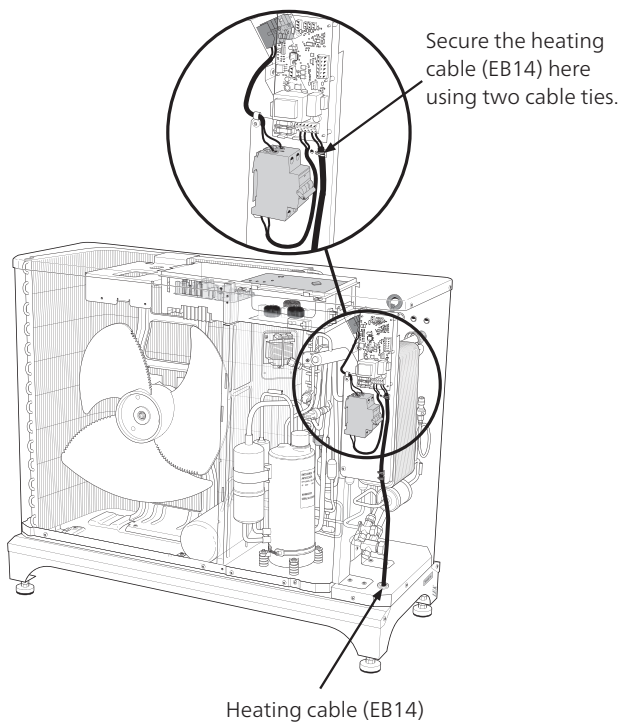

CTC CombiAir 12

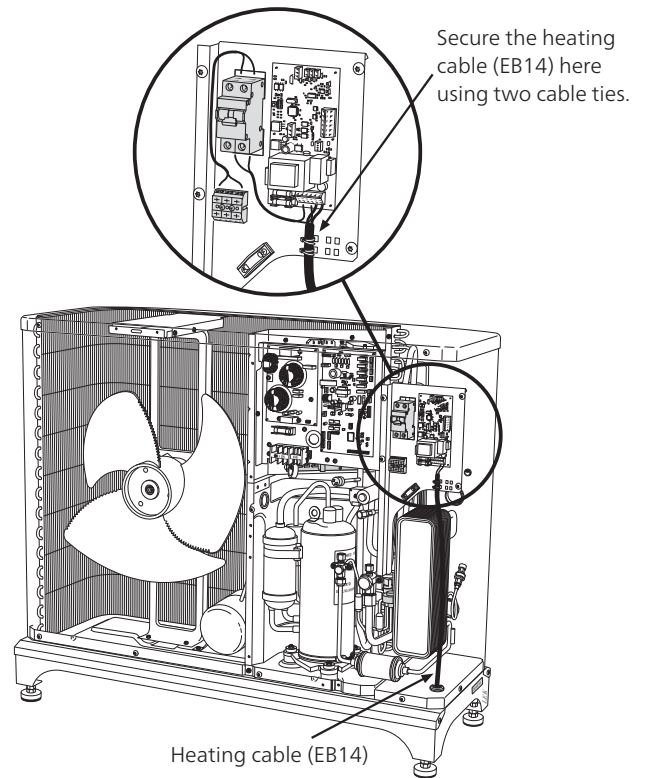

CTC CombiAir 16

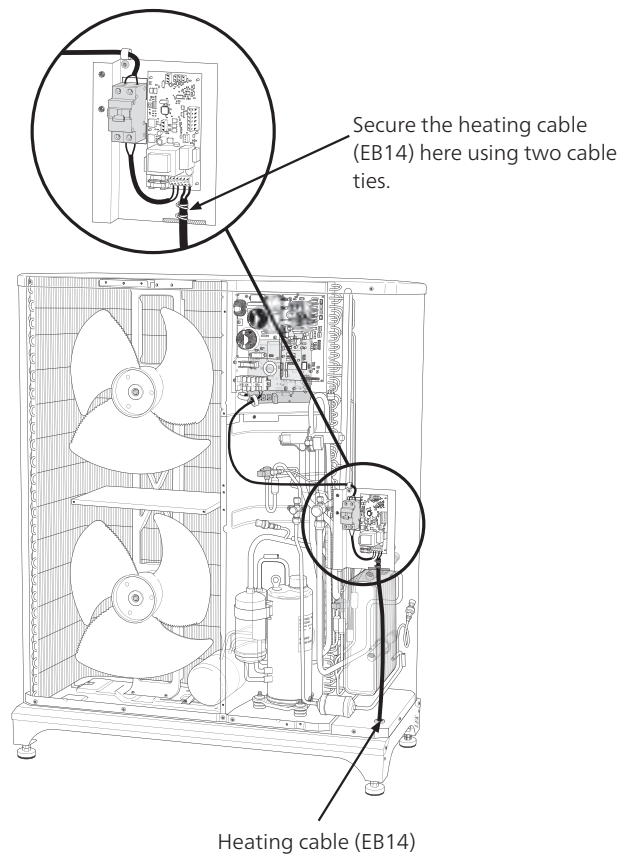

Ambient temperature sensor

An ambient temperature sensor BT28 (Tho-A) is located on the rear of CTC CombiAir .

Communication indoor module

CTC CombiAir can communicate with CTC indoor modules, by connecting the indoor module to the terminal block X4:1–3 according to the following image:

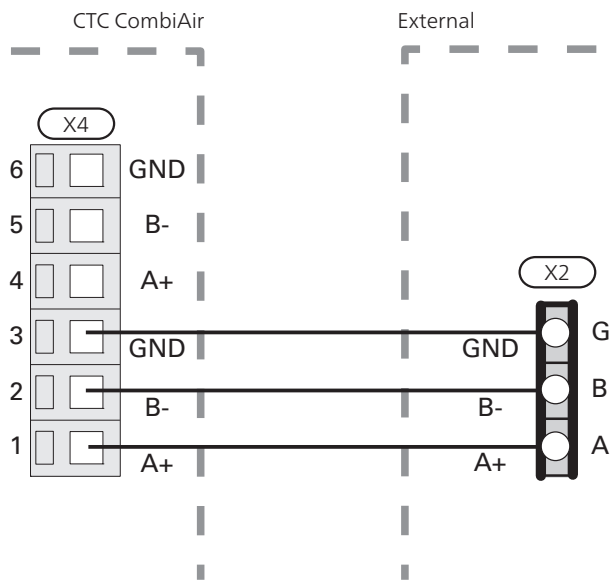

For more information, see the manual for the controlling product.

Connection between CTC CombiAir and control module



NOTE

When installing CTC CombiAir, the CTC control module must have the correct software version. Please ensure that the control module, in this case, has at least software version 2020-06-01.

The cable between the units must be connected between the terminal block for communication (AA23-X4:1, 2, 3) in CTC CombiAir and the terminal block for communication (A2-G52(A), -G51 (B), -G53 (GND)) in CTC EcoLogic M, L.

CTC CombiAir

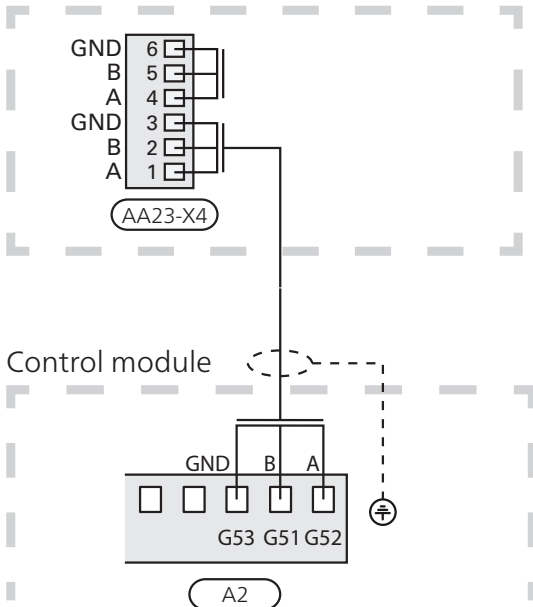

CTC EcoLogic M, L and several CTC CombiAir

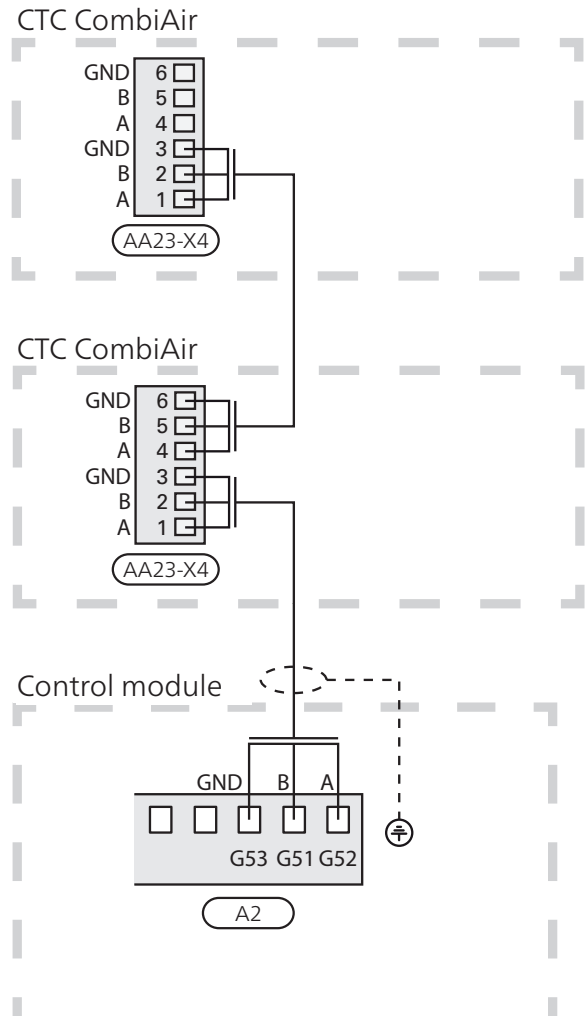

Addressing via cascade connection

On the communication board (AA23-S3), the communication address is selected for CTC CombiAir to the control module. The default address for CTC CombiAir is **1**. In a cascade connection, all CTC CombiAir must have a unique address. The address is coded in binary. Heat pumps can also be named via the software from the control module. This assumes that heat pump 1 (Address 1) is set by default (Off/Off/Off).

For more information, see the Installation and Maintenance Instructions for the control module.

Address	S3:1	S3:2	S3:3
1	OFF	OFF	OFF
2	On	OFF	OFF
3	OFF	On	OFF
4	On	On	OFF
5	OFF	OFF	On
6	On	OFF	On
7	OFF	On	On
8	On	On	On

6 Commissioning and adjusting

Preparations

- Before commissioning, check that the charge circuit and climate system are filled and well vented.
- Check the pipe system for leaks.

Filling and venting

Filling and venting the heating medium system.

1. The heating medium system is filled with water to the required pressure.
2. Vent the system using the venting nipple (QM20) on the enclosed flexible hose and possibly the circulation pump.

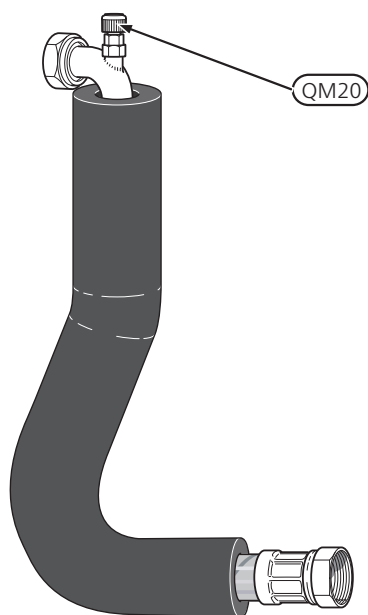

Compressor heater

CTC CombiAir (does not apply to CTC CombiAir 6) is equipped with a compressor heater that heats the compressor before start-up and when the compressor is cold.



NOTE

The compressor heater must have been connected for 6 – 8 hours before the first start, see the section "Start-up and inspection" in the Installer Manual for the indoor section

Start-up and inspection

1. The compressor heater (CH) must have been operational for at least 6 - 8 hours before the compressor start can be initiated. This is done by switching on the control voltage and disconnecting the communication cable.
2. The communication cable on the terminal block AA23-X4 must not be connected.
3. Turn the isolator switch on.
4. Ensure that the CTC CombiAir is connected to the power source.
5. After 6 – 8 hours, connect the communication cable (W2) to the terminal block AA23-X4.
6. Restart the indoor module. Follow the instructions for "Start-up and inspection" in the installation manual for the indoor module.

The heat pump starts 30 minutes after the outdoor unit has been powered up and the communication cable (W2) has been connected, if necessary.

If scheduled *silent operation* is required, it must be scheduled in the inner section or control unit.



Caution

Silent mode should only be scheduled periodically because the maximum output is limited to approx. the nominal values.



Caution

Do not start any electrical work until at least two minutes after cutting the power.

CTC CombiAir 6 , 8

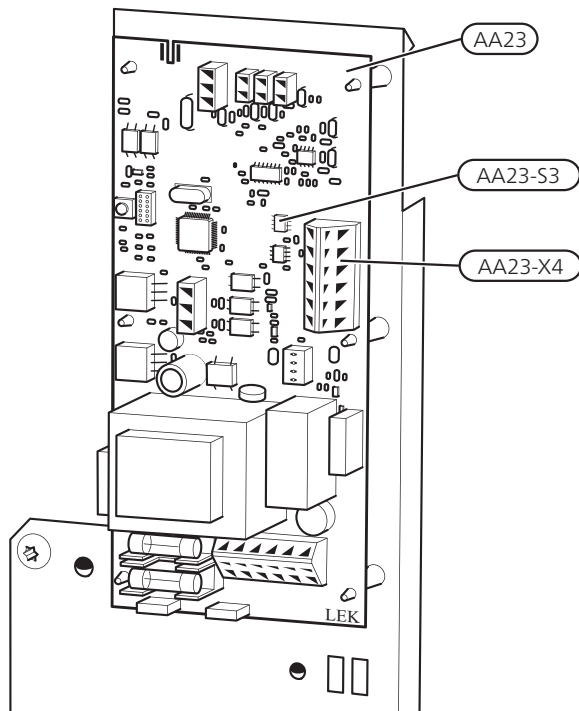

CTC CombiAir 12 , 16

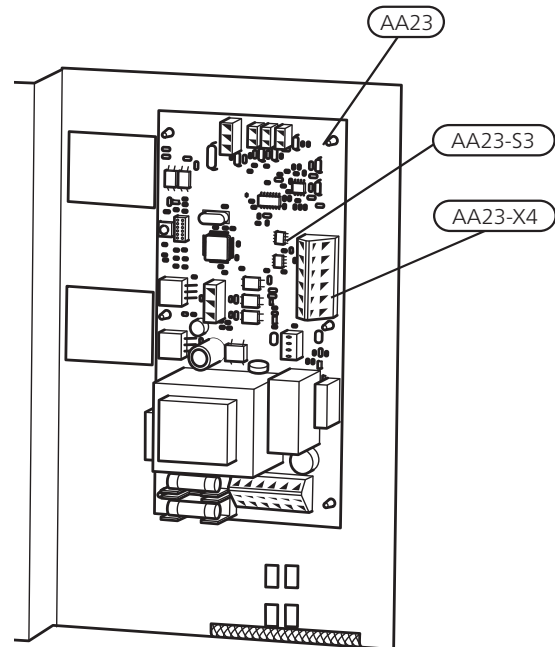

Readjusting, heating medium side

Air is initially released from the hot water and venting may be necessary. If bubbling sounds can be heard from the heat pump, the circulation pump and radiators the entire system will require further venting. When the system is stable (correct pressure and all air eliminated) the automatic heating control system can be set as required.

Adjustment, charge flow

Instructions for adjusting hot water charging are in the Installer Manual for the relevant indoor module. See section Accessories for a list of the indoor units and accessories that can be connected to CTC CombiAir .

7 Control

For information about display settings, see the manual for the controlling product.

8 Disturbances in comfort

Troubleshooting



NOTE

Work behind covers secured by screws may only be carried out by, or under the supervision of, a qualified installation engineer.



NOTE

As CTC CombiAir can be connected to a large number of external units, these should also be checked.



NOTE

In the event of action to rectify malfunctions that require work within screwed hatches the incoming electricity must be isolated at the safety switch.

The following tips can be used to rectify comfort disruption:

Basic actions

CTC CombiAir not in operation

- Ensure that the CTC CombiAir is connected to the power source and that compressor operation is required.

CTC CombiAir does not communicate

- Check that the addressing of CTC CombiAir is correct.
- Check that the communication cable is correctly connected and working.

Further possible measures

If any components are disconnected from the power.

Start by checking the following items:

- That the heat pump is running or that the supply cable to CTC CombiAir is connected.
 - That the feed cable is connected to CTC CombiAir.
- Group and main fuses of the accommodation.
- The heat pump's fuse (F).
- The main product's fuses.
- The property's earth circuit breaker.
- The main product's temperature limiter.

Low hot water temperature or a lack of hot water



Caution

This part of the fault-tracing chapter only applies if the heat pump is docked to the hot water heater.

- Large hot water consumption.
 - Wait until the hot water has heated up.
- The hot water settings are adjusted on the display on the indoor module / control module.
 - See the manual for the indoor module or control module.

Low room temperature

- Closed thermostats in several rooms.
 - Set the thermostats to max in as many rooms as possible.
- Incorrect settings in indoor module or control module.

High room temperature

- Incorrect settings in indoor module or control module.
 - See the manual for the indoor module or control module.

Large amount of water below CTC CombiAir

Check that the water drainage via the condensation pipe (KVR) is working.

Sensor placement

Sensors etc.

BE1 (CT)	Current sensor
BP1 (63H1)	High pressure pressostat
BP2 (LPT)	Low pressure transmitter
BP4	High pressure sensor
BT3	Temperature sensor, heating medium return line
BT12	Temperature sensor, condenser supply line
BT14 (Tho-D)	Temperature sensor, hot gas
BT15	Temperature sensor, fluid pipe
BT16 (Tho-R1)	Temperature sensor, heat exchanger, 1
BT17 (Tho-S)	Temperature sensor, suction gas
BT28 (Tho-A)	Temperature sensor, ambient
EB10 (CH)	Compressor heater
EB11 (DH)	Drip tray heater
EP2	Condenser
GQ1 (FM01)	Fan
GQ10 (CM)	Compressor
HS1	Drying filter
QN1 (EEV)	Expansion valve
QN1 (SM2)	Expansion valve, heating
QN2 (20S)	4-way valve
QN3 (SM1)	Expansion valve, cooling
Tho-R2	Temperature sensor, heat exchanger, 2

Designations according to standard EN 81346-2.

Designations within brackets according to the supplier's standard.

Connection to board (PWB1)

CTC CombiAir 6

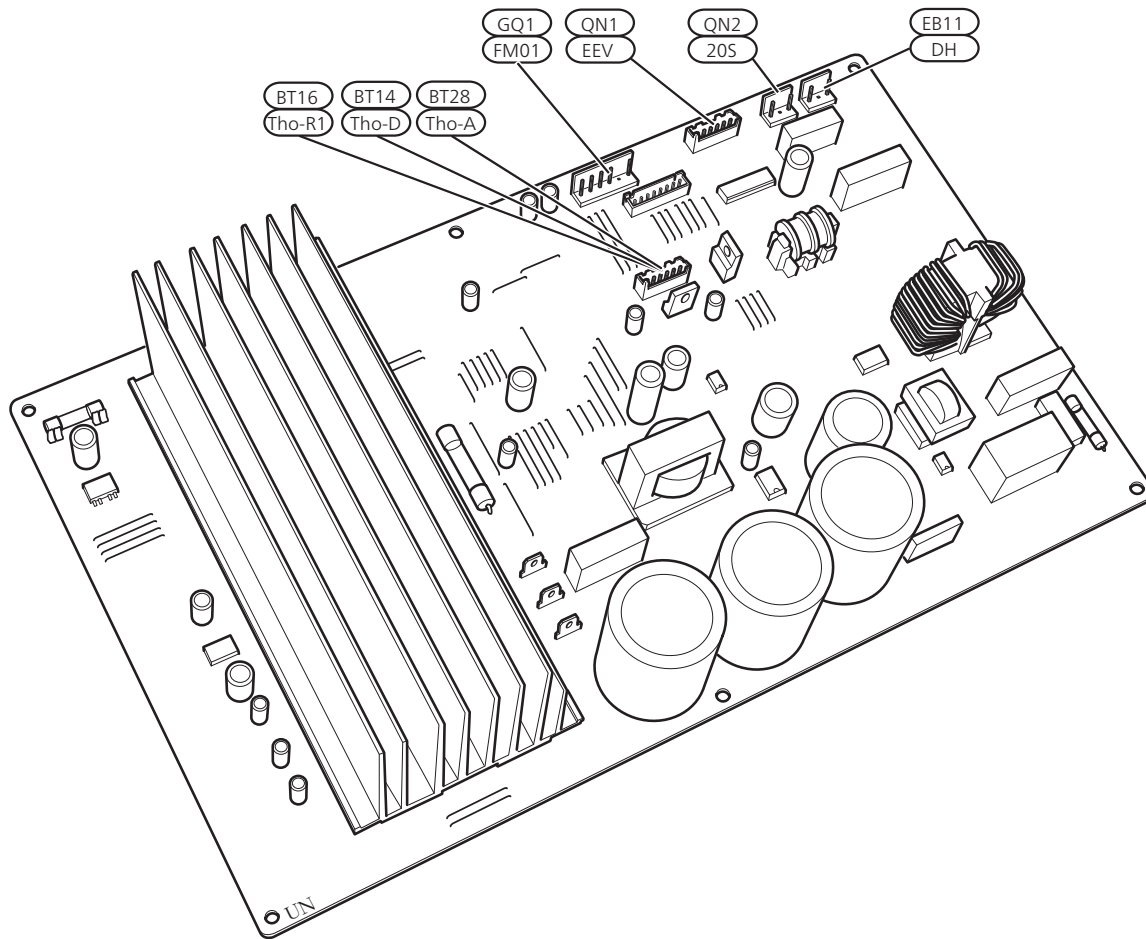

CTC CombiAir 8

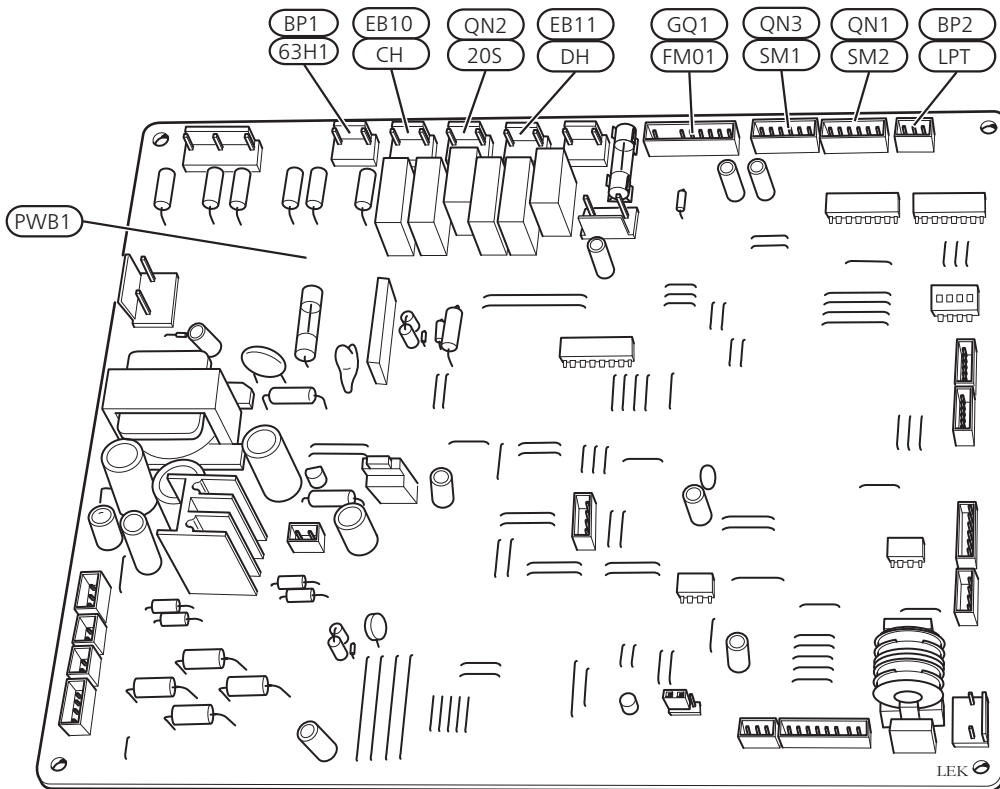

CTC CombiAir 12 / CTC CombiAir 16

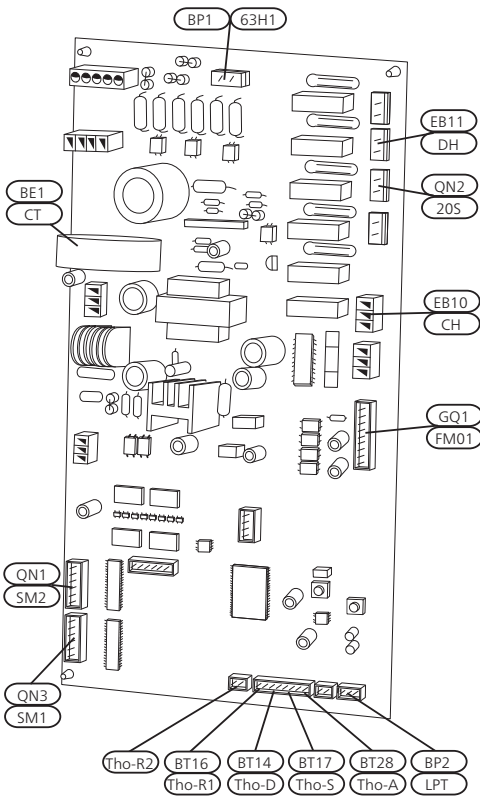

Connection to board (AA23)

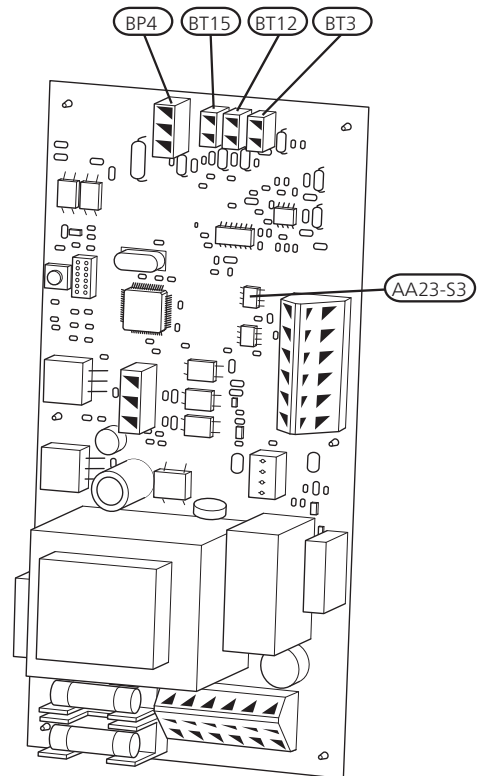

Sensor placement in CTC CombiAir

Outdoor module CTC CombiAir -6

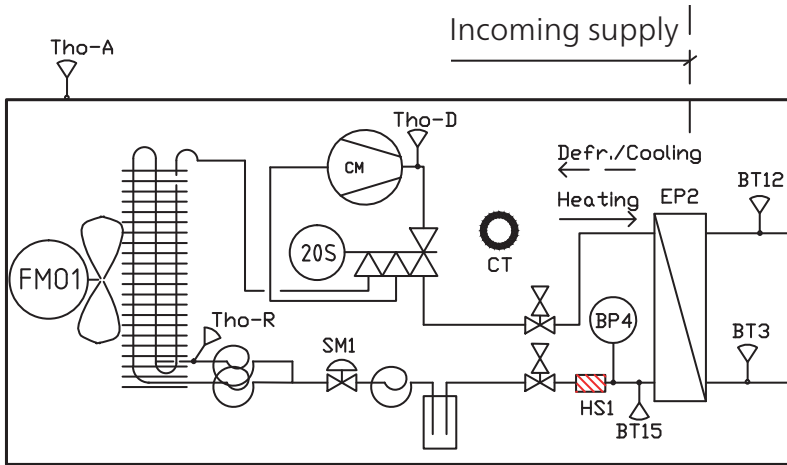

Outdoor module CTC CombiAir -8, -12

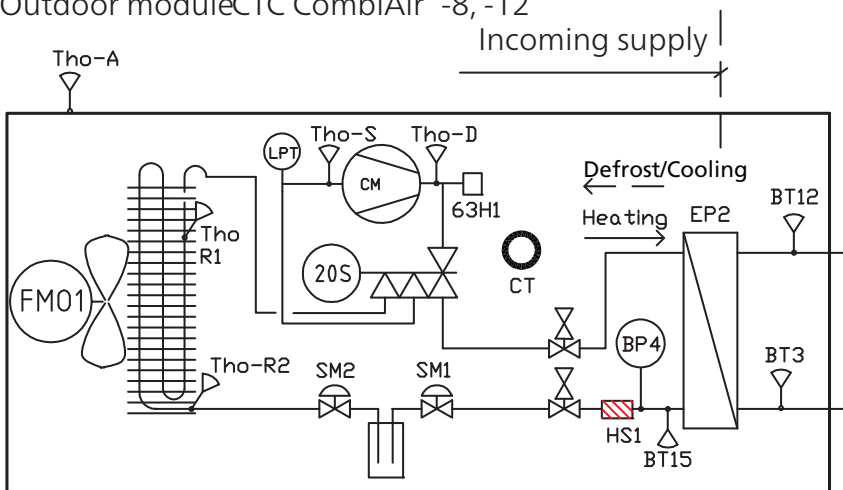

Outdoor module CTC CombiAir -16

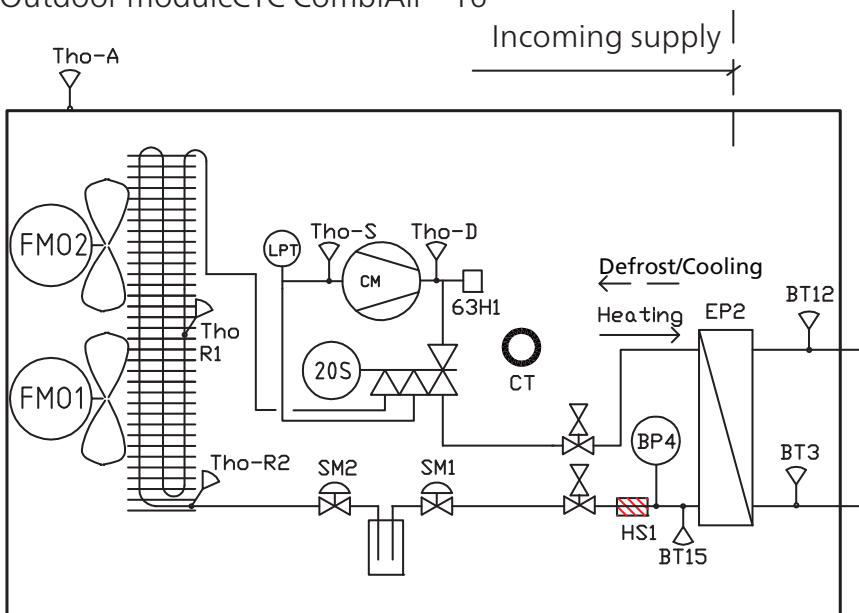

Data for temperature sensor in CTC CombiAir 6

Tho-D

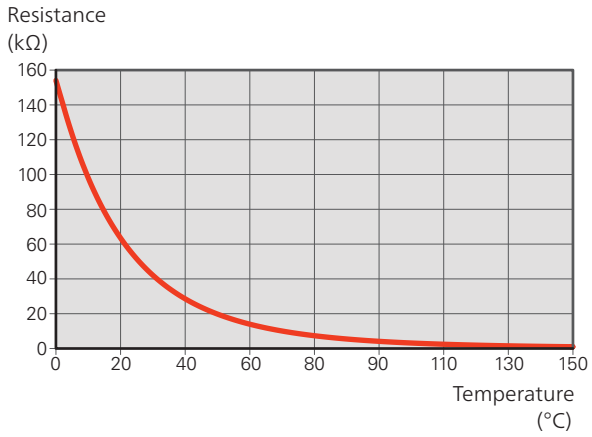

Data for temperature sensor in CTC CombiAir 8, 12, 16

Tho-D

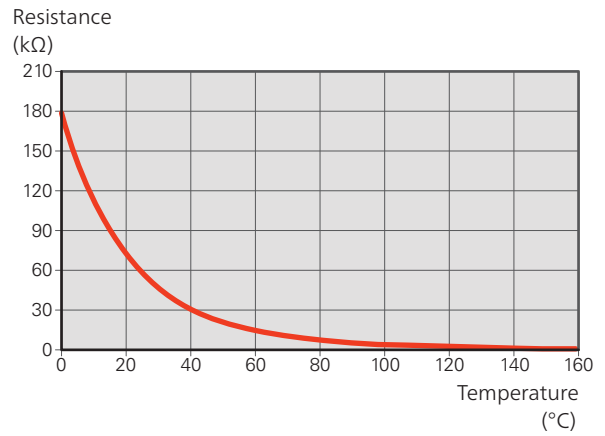

Tho-A, R

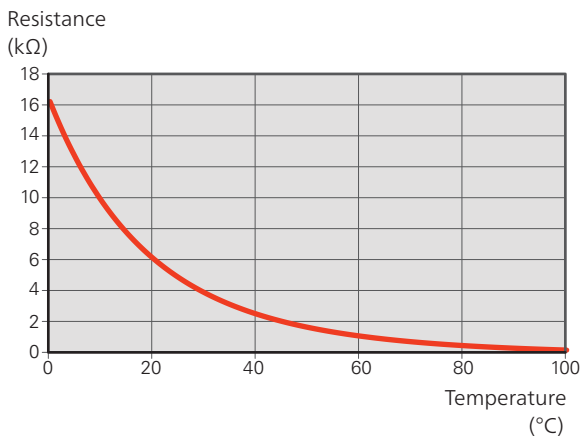

Tho-S, Tho-R1, Tho-R2

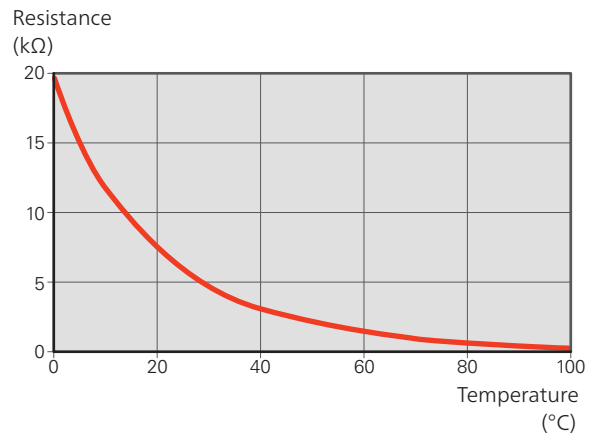

BT28 (Tho-A)

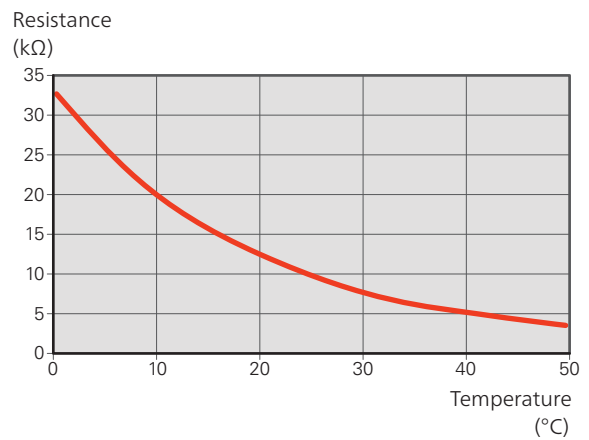

**Data for return line temperature sensor (BT3),
condensor supply (BT12) and fluid pipe (BT15)**

Temperature (°C)	Resistance (kOhm)	Voltage (VDC)
-40	351.0	3.256
-35	251.6	3.240
-30	182.5	3.218
-25	133.8	3.189
-20	99.22	3.150
-15	74.32	3.105
-10	56.20	3.047
-5	42.89	2.976
0	33.02	2.889
5	25.61	2.789
10	20.02	2.673
15	15.77	2.541
20	12.51	2.399
25	10.00	2.245
30	8.045	2.083
35	6.514	1.916
40	5.306	1.752
45	4.348	1.587
50	3.583	1.426
55	2.968	1.278
60	2.467	1.136
65	2.068	1.007
70	1.739	0.891
75	1.469	0.785
80	1.246	0.691
85	1.061	0.607
90	0.908	0.533
95	0.779	0.469
100	0.672	0.414

9 Alarm list

See alarm list in the manual for the controlling product.

10 Accessories

Ground stand

Ground stand

CTC CombiAir 6, 8, 12, 16

Part no. 589340301

Wall bracket

Wall mounting of CTC CombiAir .

Part no. 589341301

Condensation water pipe - KVR

1-phase

Condensation water pipe, different lengths.

Earth circuit breaker 1-phase.

KVR, 1 metre

Part no. 589342301

KVR, 3 metres

Part no. 589342302

KVR, 6 metres

Part no. 589342303

2-phase

Condensation water pipe, different lengths.

Earth circuit breaker 2-phase.

KVR, 1 metre

Part no. 589342304

KVR, 3 metres

Part no. 589342305

KVR, 6 metres

Part no. 589342306

For more information, see ctc-heating.com.

11 Technical data

Dimensions and setting-out coordinates

CTC CombiAir 6

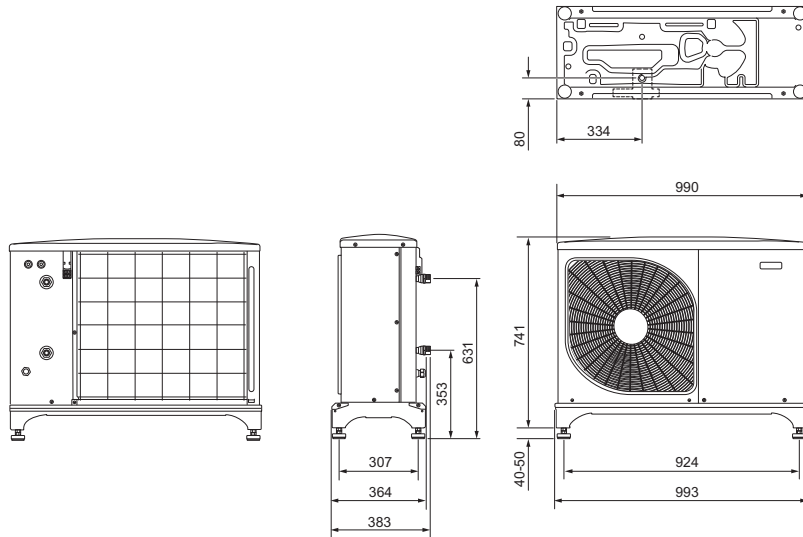

*Requires accessory KVR.

CTC CombiAir 8

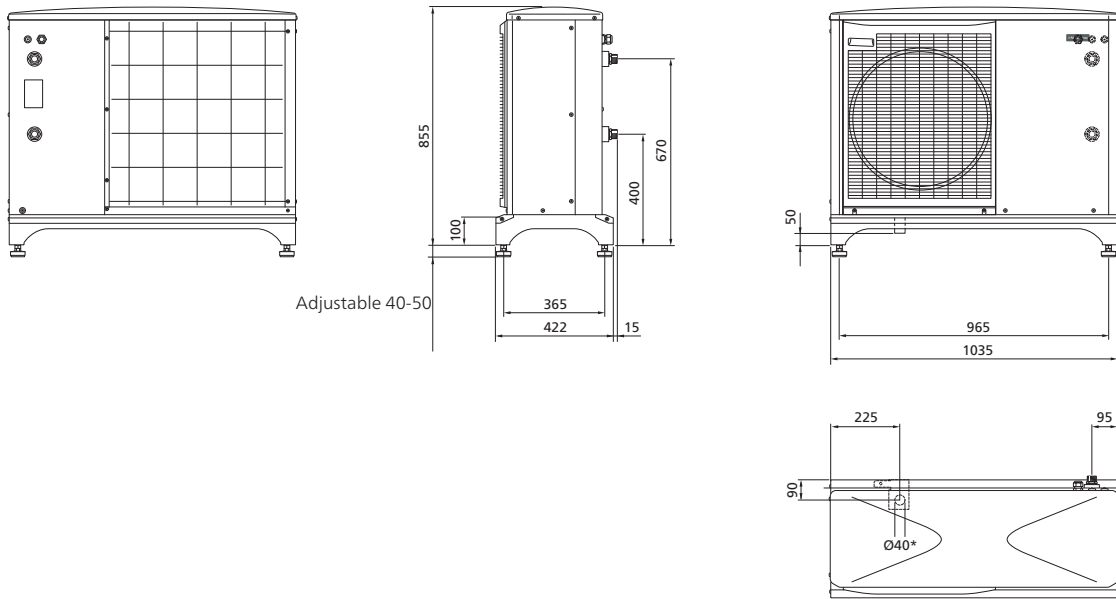

*Requires accessory KVR.

CTC CombiAir 12

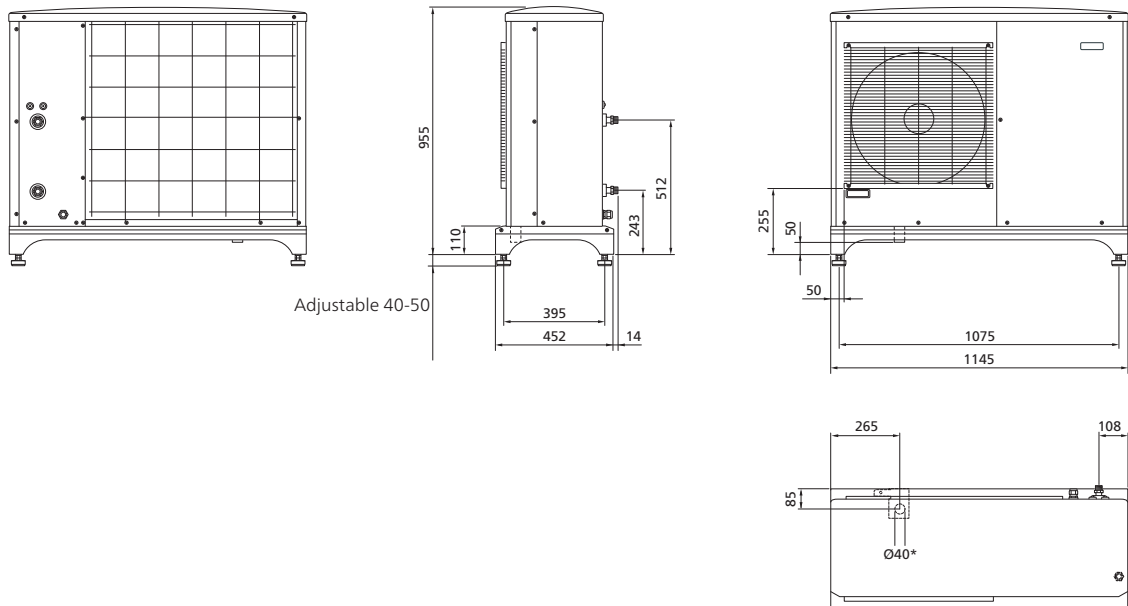

*Requires accessory KVR.

CTC CombiAir 16

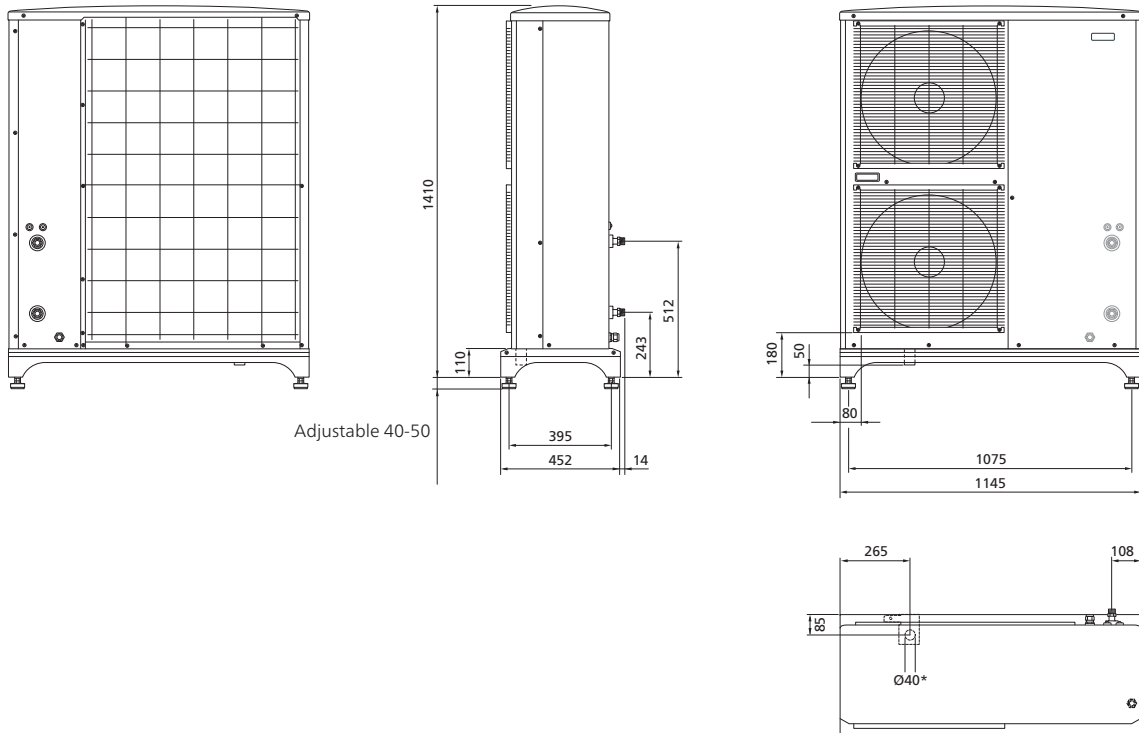

*Requires accessory KVR.

Sound levels

CTC CombiAir is usually placed next to a house wall, which gives a directed sound distribution that should be considered. Accordingly, you should always attempt when positioning to choose the side that faces the least sound sensitive neighbouring area.

The sound pressure levels are further affected by walls, bricks, differences in ground level, etc and should therefore only be seen as guide values.

CTC CombiAir adjusts the fan speed depending on the ambient temperature and evaporation temperature.

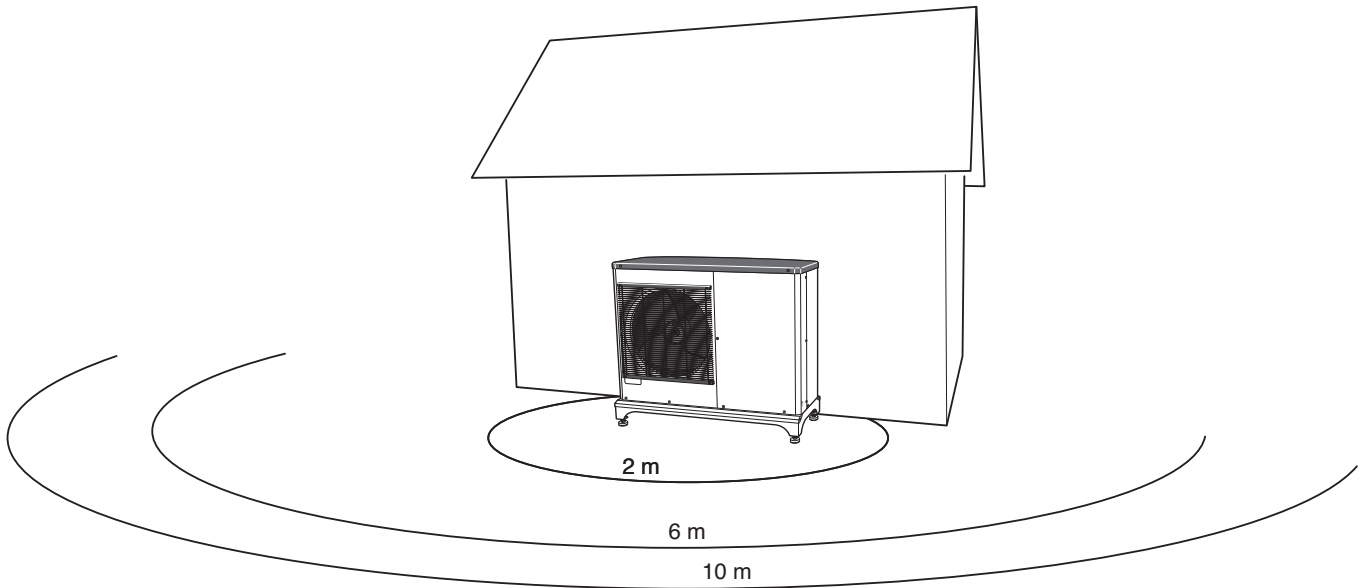

Air/water heat pump		CTC Combi-Air 6	CTC Combi-Air 8	CTC Combi-Air 12	CTC Combi-Air 16
Sound power level* According to EN12102 at 7/45 (nominal)	$L_W(A)$	50	54	57	61
Sound pressure level at 2 m free standing.*	dB(A)	36	40	43	47
Sound pressure level at 6 m free standing.*	dB(A)	26.5	30.5	33.5	37.5
Sound pressure level at 10 m free standing.*	dB(A)	22	26	29	33

* Free space.

Technical specifications

Air/water heat pump		CTC Combi-Air 6	CTC Combi-Air 8	CTC Combi-Air 12	CTC Combi-Air 16
<i>Output data according to EN 14511 ΔT_{5K}</i>					
	Outdoor temp./ Supply temp.				
<i>Heating</i> Capacity / power input / COP (kW/kW/-) at nominal flow	7/35 °C (floor)	2.67/0.50/5.32	3.86/0.83/4.65	5.21/1.09/4.78	7.03/1.45/4.85
	2/35 °C (floor)	2.32/0.55/4.20	5.11/1.36/3.76	6.91/1.79/3.86	9.33/2.38/3.92
	-7/35 °C (floor)	4.60/1.79/2.57	6.60/2.46/2.68	9.00/3.27/2.75	12.1/4.32/2.80
	7/45 °C	2.28/0.63/3.62	3.70/1.00/3.70	5.00/1.31/3.82	6.75/1.74/3.88
	2/45 °C	1.93/0.67/2.88	5.03/1.70/2.96	6.80/2.24/3.04	9.18/2.98/3.08
<i>Cooling</i> Capacity / Power input / EER (kW/kW/-) at maximum flow	27/7 °C	5.87/1.65/3.56	7.52/2.37/3.17	9.87/3.16/3.13	13.30/3.99/3.33
	27/18 °C	7.98/1.77/4.52	11.20/3.20/3.50	11.70/3.32/3.52	17.70/4.52/3.91
	35/7 °C	4.86/1.86/2.61	7.10/2.65/2.68	9.45/3.41/2.77	13.04/4.53/2.88
	35/18 °C	7.03/2.03/3.45	9.19/2.98/3.08	11.20/3.58/3.12	15.70/5.04/3.12
<i>Electrical data</i>					
Rated voltage		230V ~ 50Hz, 230V 2 ~ 50Hz			
Max operating current, heat pump	A_{rms}	15	16	23	25
Max operating current, compressor	A_{rms}	14	15	22	24
Starting current	A_{rms}	5			
Nominal output, fan	W	50	86	86	2 x 86
Fuse ¹⁾	A_{rms}	16	16	25	25
Enclosure class		IP24			
<i>Refrigerant circuit</i>					
Type of refrigerant		R410A			
GWP refrigerant		2,088			
Type of compressor		Twin Rotary			
Compressor oil		M-MA68			
Volume	kg	1.5	2.55	2.9	4.0
CO ₂ equivalent	t	3.13	5.32	6.06	8.35
Cut-out value pressostat HP	MPa	-	4.15 (41.5 bar)		
Cut-out value HP		4.15 (41.5 bar)		-	
Cut-out value pressostat LP	MPa	-	0.079 (0.79 bar)		
<i>Brine</i>					
Airflow	m ³ /h	2,530	3,000	4,380	6,000
Min. / Max. air temp.	°C	-20 / 43			
Defrosting system		Reverse cycle			
<i>Heating medium circuit</i>					
Min/Max system pressure heating medium		0.05/0.25 (0.5/4.5bar)			
Min volume, climate system, heating/cooling		20	50	80	150
Min volume, climate system, under floor cooling		50	80	100	150
Max flow, climate system		0.29	0.38	0.57	0.79
Min flow, climate system, at 100% circulation pump speed (defrosting flow)		0.19	0.19	0.29	0.39
Min flow, heating		0.09	0.12	0.15	0.25
Min flow, cooling		0.11	0.15	0.20	0.32
Min. / Max. HM temp continuous operation		25 / 58			
Connection heating medium ext thread		G1"			
<i>Dimensions and weight</i>					
Width	mm	993	1035	1145	1145
Depth	mm	364	422	452	452
Height with stand	mm	791 (+50/-0)	895 (+50/-0)	995 (+50/-0)	1450 (+50/-0)
Weight (excl. packaging)	kg	66	90	105	135
<i>Miscellaneous</i>					
Substances according to Directive (EG) no. 1907/2006, article 33 (Reach)		Lead in brass components			
Part No.		589350001	589351001	589352001	589353001

¹⁾Specified output is limited with lower fusing.

SCOP & P_{designh}

SCOP & P _{designh} CTC CombiAir according to EN 14825								
CTC CombiAir	6		8		12		16	
	P _{designh}	SCOP	P _{designh}	SCOP	P _{designh}	SCOP	P _{designh}	SCOP
SCOP 35 Average climate	4.8	4.79	8.2	4.37	11.5	4.43	14.5	4.48
SCOP 55 Average climate	5.3	3.36	7.0	3.26	10	3.37	14	3.43
SCOP 35 Cold climate	4.0	3.68	9	3.39	11.5	3.41	15	3.48
SCOP 55 Cold climate	5.6	2.98	10	2.72	13	2.75	16	2.77
SCOP 35 Warm climate	4.2	6.39	8	5.75	12	5.80	15	5.99
SCOP 55 Warm climate	4.8	4.55	8	4.55	12	4.65	15	4.79

Energy rating, average climate

Model		CTC CombiAir 6	CTC CombiAir 8	CTC CombiAir 12	CTC CombiAir 16
Temperature application	°C	35 / 55	35 / 55	35 / 55	35 / 55
The product's room heating efficiency class ¹⁾		A+++ / A++	A++ / A++	A++ / A++	A+++ / A++
Space heating efficiency class of the system ²⁾		A+++ / A++	A+++ / A++	A+++ / A++	A+++ / A++

¹⁾Scale for the product's room heating efficiency class A++ to G.

²⁾Scale for the system's room heating efficiency class A+++ to G.

The reported efficiency of the package also takes the controller into account. If an external supplementary boiler or solar heating is added to the package, the overall efficiency of the package should be recalculated.

Working area

Compressor operation – heating

Water temperature (°C)

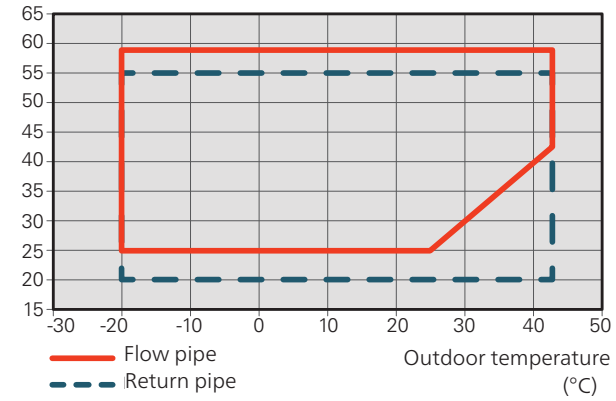

During shorter time it is allowed to have lower working temperatures on the water side, e.g. during start up.

Compressor operation – cooling

Water temperature (°C)

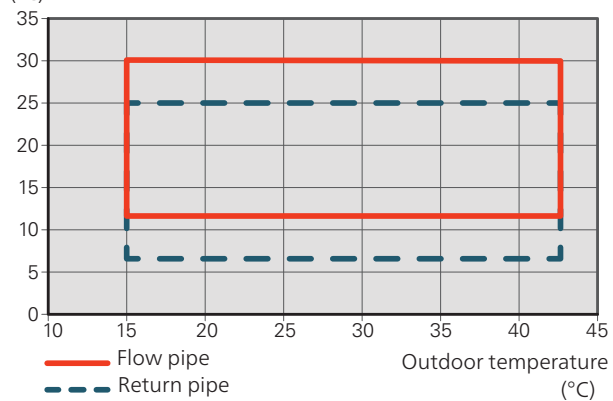

Capacity and COP

Capacity and COP at different supply temperatures. Maximum capacity including defrosting. According to standard EN 14511.

Max. capacity CTC CombiAir 6

Heating output (kW)

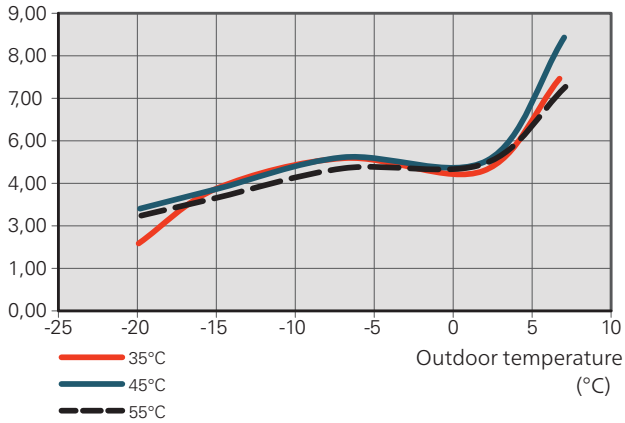

COP CTC CombiAir 6

COP

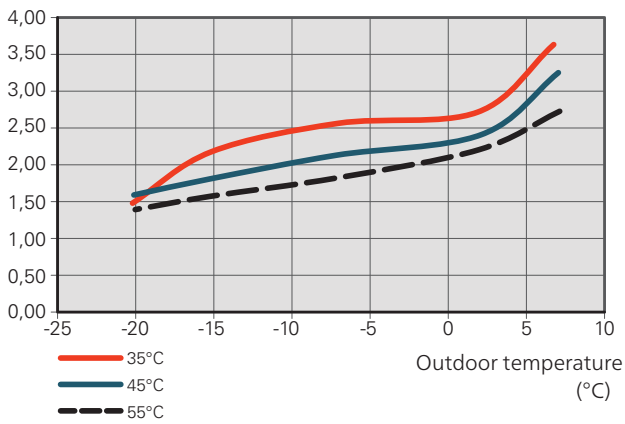

Max. capacity CTC CombiAir 8

Heating output (kW)

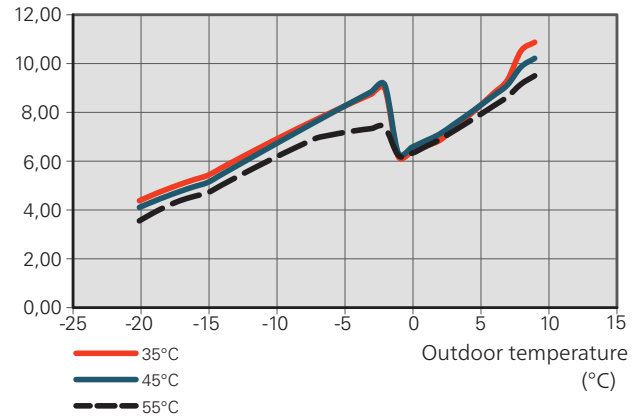

COP CTC CombiAir 8

COP

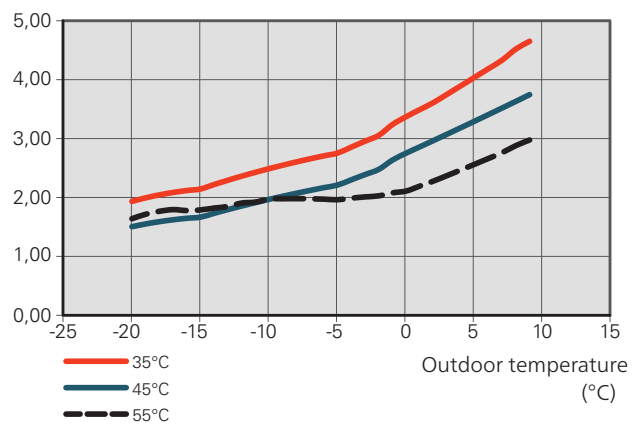

Max. capacity CTC CombiAir 12

Heating output
(kW)

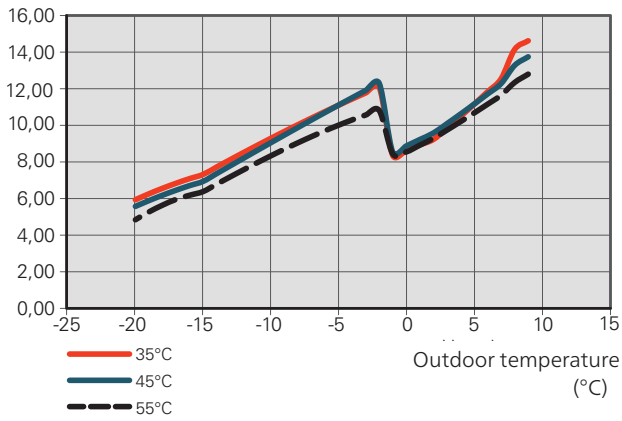

Max. capacity CTC CombiAir 16

Heating output
(kW)

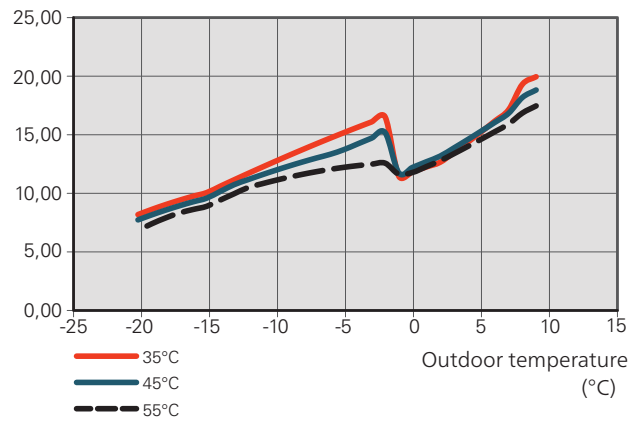

COP CTC CombiAir 12

COP

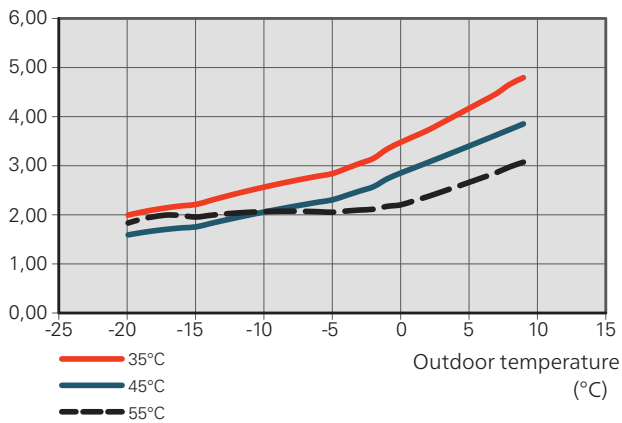

COP CTC CombiAir 16

COP

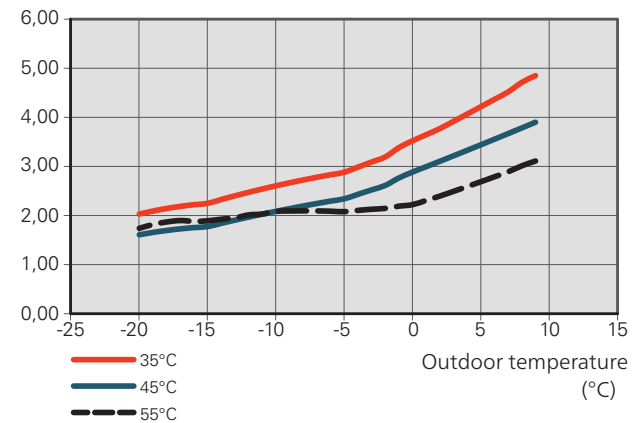

Output with lower fuse rating than recommended

Supplied power CTC CombiAir 12, fuse rating 16A

Heating output (kW)

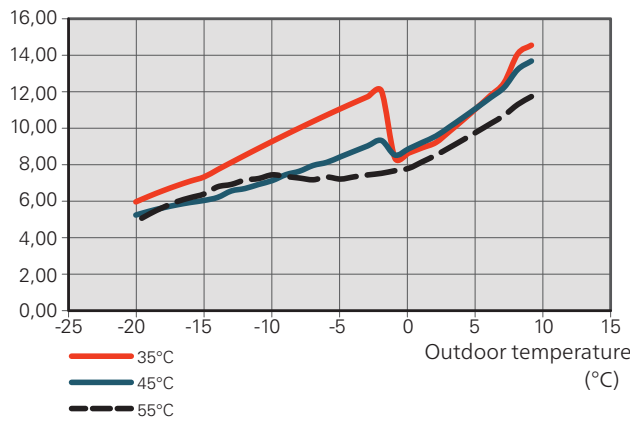

Supplied power CTC CombiAir 12, fuse rating 20A

Heating output (kW)

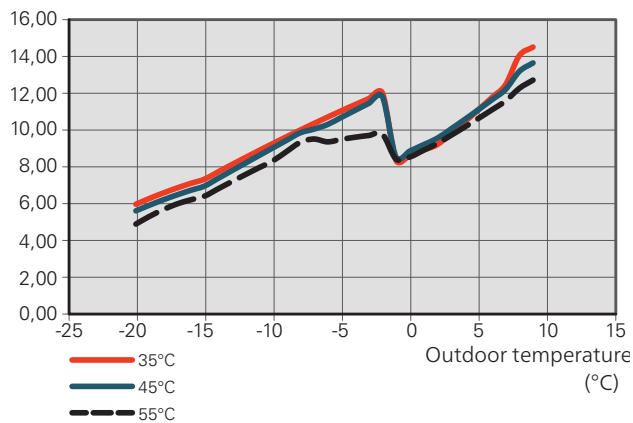

Supplied power CTC CombiAir 16, fuse rating 20A

Heating output (kW)

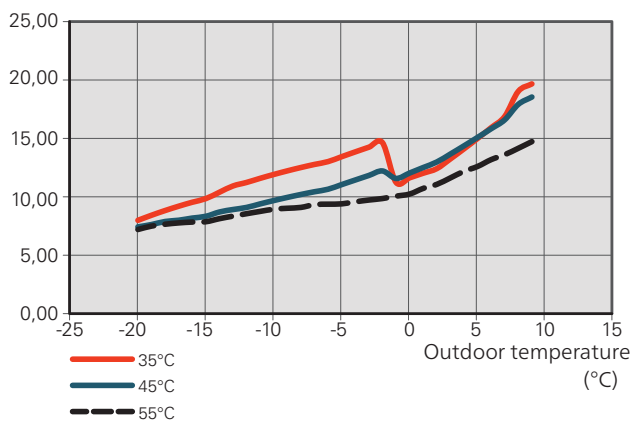

Energy labelling

Information sheet

Supplier		CTC			
Model		CTC CombiAir 6	CTC CombiAir 8	CTC CombiAir 12	CTC CombiAir 16
Temperature application	°C	35 / 55	35 / 55	35 / 55	35 / 55
Seasonal space heating energy efficiency class, average climate		A++ / A++	A++ / A++	A++ / A++	A++ / A++
Rated heat output (P_{designh}), average climate	kW	5 / 5	8 / 7	12 / 10	15 / 14
Annual energy consumption space heating, average climate	kWh	2,072 / 3,245	3,874 / 4,435	5,361 / 6,137	6,691 / 8,428
Seasonal space heating energy efficiency, average climate	%	188 / 131	172 / 127	174 / 132	176 / 134
Sound power level L_{WA} indoors	dB	35	35	35	35
Rated heat output (P_{designh}), cold climate	kW	4 / 6	9 / 10	12 / 13	15 / 16
Rated heat output (P_{designh}), warm climate	kW	4 / 5	8 / 8	12 / 12	15 / 15
Annual energy consumption space heating, cold climate	kWh	2,694 / 4,555	6,552 / 9,064	8,302 / 11,639	10,628 / 14,220
Annual energy consumption space heating, warm climate	kWh	870 / 1,398	1,860 / 2,350	2,765 / 3,445	3,344 / 4,186
Seasonal space heating energy efficiency, cold climate	%	143 / 117	132 / 106	134 / 107	136 / 108
Seasonal space heating energy efficiency, warm climate	%	252 / 179	227 / 179	229 / 183	237 / 188
Sound power level L_{WA} outdoors	dB	50	54	57	61

Data for energy efficiency of the package

Model		CTC CombiAir 6	CTC CombiAir 8	CTC CombiAir 12	CTC CombiAir 16
Control module model		CTC EcoLogic M, L	CTC EcoLogic M, L	CTC EcoLogic M, L	CTC EcoLogic M, L
Temperature application	°C	35 / 55	35 / 55	35 / 55	35 / 55
Controller, class		VI			
Controller, contribution to efficiency	%	4.0			
Seasonal space heating energy efficiency of the package, average climate	%	192 / 135	176 / 131	178 / 136	180 / 138
Seasonal space heating energy efficiency class of the package, average climate		A+++ / A++	A+++ / A++	A+++ / A++	A+++ / A++
Seasonal space heating energy efficiency of the package, cold climate	%	147 / 121	136 / 110	138 / 111	140 / 112
Seasonal space heating energy efficiency of the package, warm climate	%	256 / 183	231 / 183	233 / 187	241 / 192

The reported efficiency of the package also takes the controller into account. If an external supplementary boiler or solar heating is added to the package, the overall efficiency of the package should be recalculated.

Technical documentation

Model				CTC CombiAir 6							
Type of heat pump				<input checked="" type="checkbox"/> Air-water <input type="checkbox"/> Exhaust-water <input type="checkbox"/> Brine-water <input type="checkbox"/> Water-water							
Low-temperature heat pump				<input type="checkbox"/> Yes <input checked="" type="checkbox"/> No							
Integrated immersion heater for additional heat				<input type="checkbox"/> Yes <input checked="" type="checkbox"/> No							
Heat pump combination heater				<input type="checkbox"/> Yes <input checked="" type="checkbox"/> No							
Climate				<input checked="" type="checkbox"/> Average <input type="checkbox"/> Cold <input type="checkbox"/> Warm							
Temperature application				<input checked="" type="checkbox"/> Average (55 °C) <input type="checkbox"/> Low (35 °C)							
Applied standards				EN14825 / EN14511 / EN12102							
Rated heat output		Prated	5.3	kW	Seasonal space heating energy efficiency		η_s	131	%		
Declared capacity for space heating at part load and at outdoor temperature T_j				Declared coefficient of performance for space heating at part load and at outdoor temperature T_j							
$T_j = -7\text{ °C}$	Pdh	4.7	kW	$T_j = -7\text{ °C}$	COPd	1.88	-				
$T_j = +2\text{ °C}$	Pdh	2.8	kW	$T_j = +2\text{ °C}$	COPd	3.26	-				
$T_j = +7\text{ °C}$	Pdh	1.8	kW	$T_j = +7\text{ °C}$	COPd	4.72	-				
$T_j = +12\text{ °C}$	Pdh	2.7	kW	$T_j = +12\text{ °C}$	COPd	6.47	-				
$T_j = \text{biv}$	Pdh	4.7	kW	$T_j = \text{biv}$	COPd	1.88	-				
$T_j = \text{TOL}$	Pdh	4.1	kW	$T_j = \text{TOL}$	COPd	1.77	-				
$T_j = -15\text{ °C}$ (if TOL < -20 °C)	Pdh		kW	$T_j = -15\text{ °C}$ (if TOL < -20 °C)	COPd		-				
Bivalent temperature				T_{biv}	-7	°C	Min. outdoor air temperature		TOL	-10	°C
Cycling interval capacity				P _{ych}		kW	Cycling interval efficiency		COP _{yc}		-
Degradation coefficient				C _{dh}	0.99	-	Max supply temperature		WTOL	58	°C
Power consumption in modes other than active mode				Additional heat							
Off mode		P _{OFF}	0.007	kW	Rated heat output		P _{sup}	1.1	kW		
Thermostat-off mode		P _{TO}	0.012	kW							
Standby mode		P _{SB}	0.012	kW	Type of energy input		Electric				
Crankcase heater mode		P _{CK}	0	kW							
Other items											
Capacity control		Variable			Rated airflow (air-water)			2,526	m ³ /h		
Sound power level, indoors/outdoors		L _{WA}	35 / 50	dB	Nominal heating medium flow				m ³ /h		
Annual energy consumption		Q _{HE}	3,245	kWh	Brine flow brine-water or water-water heat pumps				m ³ /h		
Contact information		Enertech AB, P.O Box 309, SE-341 26 Ljungby, Sweden									

Model		CTC CombiAir 8					
Type of heat pump	<input checked="" type="checkbox"/> Air-water <input type="checkbox"/> Exhaust-water <input type="checkbox"/> Brine-water <input type="checkbox"/> Water-water						
Low-temperature heat pump	<input type="checkbox"/> Yes <input checked="" type="checkbox"/> No						
Integrated immersion heater for additional heat	<input type="checkbox"/> Yes <input checked="" type="checkbox"/> No						
Heat pump combination heater	<input type="checkbox"/> Yes <input checked="" type="checkbox"/> No						
Climate	<input checked="" type="checkbox"/> Average <input type="checkbox"/> Cold <input type="checkbox"/> Warm						
Temperature application	<input checked="" type="checkbox"/> Average (55 °C) <input type="checkbox"/> Low (35 °C)						
Applied standards	EN14511 / EN14825 / EN12102						
Rated heat output	Prated	7	kW	Seasonal space heating energy efficiency	η_s	127	%
Declared capacity for space heating at part load and at outdoor temperature T_j				Declared coefficient of performance for space heating at part load and at outdoor temperature T_j			
$T_j = -7\text{ °C}$	Pdh	6.3	kW	$T_j = -7\text{ °C}$	COPd	1.94	-
$T_j = +2\text{ °C}$	Pdh	3.9	kW	$T_j = +2\text{ °C}$	COPd	3.11	-
$T_j = +7\text{ °C}$	Pdh	2.6	kW	$T_j = +7\text{ °C}$	COPd	4.44	-
$T_j = +12\text{ °C}$	Pdh	3.7	kW	$T_j = +12\text{ °C}$	COPd	6.72	-
$T_j = \text{biv}$	Pdh	6.6	kW	$T_j = \text{biv}$	COPd	1.83	-
$T_j = \text{TOL}$	Pdh	5.9	kW	$T_j = \text{TOL}$	COPd	1.86	-
$T_j = -15\text{ °C}$ (if TOL < -20 °C)	Pdh		kW	$T_j = -15\text{ °C}$ (if TOL < -20 °C)	COPd		-
Bivalent temperature	T_{biv}	-9	°C	Min. outdoor air temperature	TOL	-10	°C
Cycling interval capacity	P _{ych}		kW	Cycling interval efficiency	COP _{ych}		-
Degradation coefficient	C _{dh}	0.97	-	Max supply temperature	WTOL	58	°C
Power consumption in modes other than active mode				Additional heat			
Off mode	P _{OFF}	0.002	kW	Rated heat output	P _{sup}	1.1	kW
Thermostat-off mode	P _{TO}	0.01	kW				
Standby mode	P _{SB}	0.015	kW	Type of energy input	Electric		
Crankcase heater mode	P _{CK}	0.03	kW				
Other items							
Capacity control	Variable			Rated airflow (air-water)		3,000	m ³ /h
Sound power level, indoors/outdoors	L _{WA}	35 / 54	dB	Nominal heating medium flow		0.6	m ³ /h
Annual energy consumption	Q _{HE}	4,435	kWh	Brine flow brine-water or water-water heat pumps			m ³ /h
Contact information	Enertech AB, P.O Box 309, SE-341 26 Ljungby, Sweden						

Model		CTC CombiAir 12					
Type of heat pump	<input checked="" type="checkbox"/> Air-water <input type="checkbox"/> Exhaust-water <input type="checkbox"/> Brine-water <input type="checkbox"/> Water-water						
Low-temperature heat pump	<input type="checkbox"/> Yes <input checked="" type="checkbox"/> No						
Integrated immersion heater for additional heat	<input type="checkbox"/> Yes <input checked="" type="checkbox"/> No						
Heat pump combination heater	<input type="checkbox"/> Yes <input checked="" type="checkbox"/> No						
Climate	<input checked="" type="checkbox"/> Average <input type="checkbox"/> Cold <input type="checkbox"/> Warm						
Temperature application	<input checked="" type="checkbox"/> Average (55 °C) <input type="checkbox"/> Low (35 °C)						
Applied standards	EN14825 / EN14511 / EN12102						
Rated heat output	Prated	10	kW	Seasonal space heating energy efficiency	η_s	132	%
Declared capacity for space heating at part load and at outdoor temperature T_j				Declared coefficient of performance for space heating at part load and at outdoor temperature T_j			
$T_j = -7\text{ °C}$	Pdh	8.9	kW	$T_j = -7\text{ °C}$	COPd	1.99	-
$T_j = +2\text{ °C}$	Pdh	5.5	kW	$T_j = +2\text{ °C}$	COPd	3.22	-
$T_j = +7\text{ °C}$	Pdh	3.5	kW	$T_j = +7\text{ °C}$	COPd	4.61	-
$T_j = +12\text{ °C}$	Pdh	5.0	kW	$T_j = +12\text{ °C}$	COPd	6.91	-
$T_j = \text{biv}$	Pdh	9.2	kW	$T_j = \text{biv}$	COPd	1.90	-
$T_j = \text{TOL}$	Pdh	8.1	kW	$T_j = \text{TOL}$	COPd	1.92	-
$T_j = -15\text{ °C}$ (if TOL < -20 °C)	Pdh		kW	$T_j = -15\text{ °C}$ (if TOL < -20 °C)	COPd		-
Bivalent temperature	T_{biv}	-8	°C	Min. outdoor air temperature	TOL	-10	°C
Cycling interval capacity	P _{ych}		kW	Cycling interval efficiency	COP _{yc}		-
Degradation coefficient	C _{dh}	0.98	-	Max supply temperature	WTOL	58	°C
Power consumption in modes other than active mode				Additional heat			
Off mode	P _{OFF}	0.002	kW	Rated heat output	P _{sup}	1.9	kW
Thermostat-off mode	P _{TO}	0.014	kW				
Standby mode	P _{SB}	0.015	kW	Type of energy input	Electric		
Crankcase heater mode	P _{CK}	0.035	kW				
Other items							
Capacity control	Variable			Rated airflow (air-water)		4,380	m ³ /h
Sound power level, indoors/outdoors	L _{WA}	35 / 57	dB	Nominal heating medium flow		0.86	m ³ /h
Annual energy consumption	Q _{HE}	6,137	kWh	Brine flow brine-water or water-water heat pumps			m ³ /h
Contact information	EnerTech AB, P.O Box 309, SE-341 26 Ljungby, Sweden						

Model		CTC CombiAir 16					
Type of heat pump	<input checked="" type="checkbox"/> Air-water <input type="checkbox"/> Exhaust-water <input type="checkbox"/> Brine-water <input type="checkbox"/> Water-water						
Low-temperature heat pump	<input type="checkbox"/> Yes <input checked="" type="checkbox"/> No						
Integrated immersion heater for additional heat	<input type="checkbox"/> Yes <input checked="" type="checkbox"/> No						
Heat pump combination heater	<input type="checkbox"/> Yes <input checked="" type="checkbox"/> No						
Climate	<input checked="" type="checkbox"/> Average <input type="checkbox"/> Cold <input type="checkbox"/> Warm						
Temperature application	<input checked="" type="checkbox"/> Average (55 °C) <input type="checkbox"/> Low (35 °C)						
Applied standards	EN14825 / EN14511 / EN12102						
Rated heat output	Prated	14	kW	Seasonal space heating energy efficiency	η_s	134	%
Declared capacity for space heating at part load and at outdoor temperature T_j				Declared coefficient of performance for space heating at part load and at outdoor temperature T_j			
$T_j = -7\text{ °C}$	Pdh	12.5	kW	$T_j = -7\text{ °C}$	COPd	2.01	-
$T_j = +2\text{ °C}$	Pdh	7.6	kW	$T_j = +2\text{ °C}$	COPd	3.29	-
$T_j = +7\text{ °C}$	Pdh	4.9	kW	$T_j = +7\text{ °C}$	COPd	4.68	-
$T_j = +12\text{ °C}$	Pdh	6.8	kW	$T_j = +12\text{ °C}$	COPd	7.03	-
$T_j = \text{biv}$	Pdh	12.7	kW	$T_j = \text{biv}$	COPd	1.95	-
$T_j = \text{TOL}$	Pdh	11.0	kW	$T_j = \text{TOL}$	COPd	1.95	-
$T_j = -15\text{ °C}$ (if TOL < -20 °C)	Pdh		kW	$T_j = -15\text{ °C}$ (if TOL < -20 °C)	COPd		-
Bivalent temperature	T_{biv}	-8	°C	Min. outdoor air temperature	TOL	-10	°C
Cycling interval capacity	P _{ych}		kW	Cycling interval efficiency	COP _{yc}		-
Degradation coefficient	C _{dh}	0.98	-	Max supply temperature	WTOL	58	°C
Power consumption in modes other than active mode				Additional heat			
Off mode	P _{OFF}	0.002	kW	Rated heat output	P _{sup}	3.0	kW
Thermostat-off mode	P _{TO}	0.016	kW				
Standby mode	P _{SB}	0.015	kW	Type of energy input	Electric		
Crankcase heater mode	P _{CK}	0.035	kW				
<i>Other items</i>							
Capacity control	Variable			Rated airflow (air-water)		6,000	m ³ /h
Sound power level, indoors/outdoors	L _{WA}	35 / 61	dB	Nominal heating medium flow		1.21	m ³ /h
Annual energy consumption	Q _{HE}	8,428	kWh	Brine flow brine-water or water-water heat pumps			m ³ /h
Contact information	EnerTech AB, P.O Box 309, SE-341 26 Ljungby, Sweden						

Electrical circuit diagram

CTC CombiAir 6

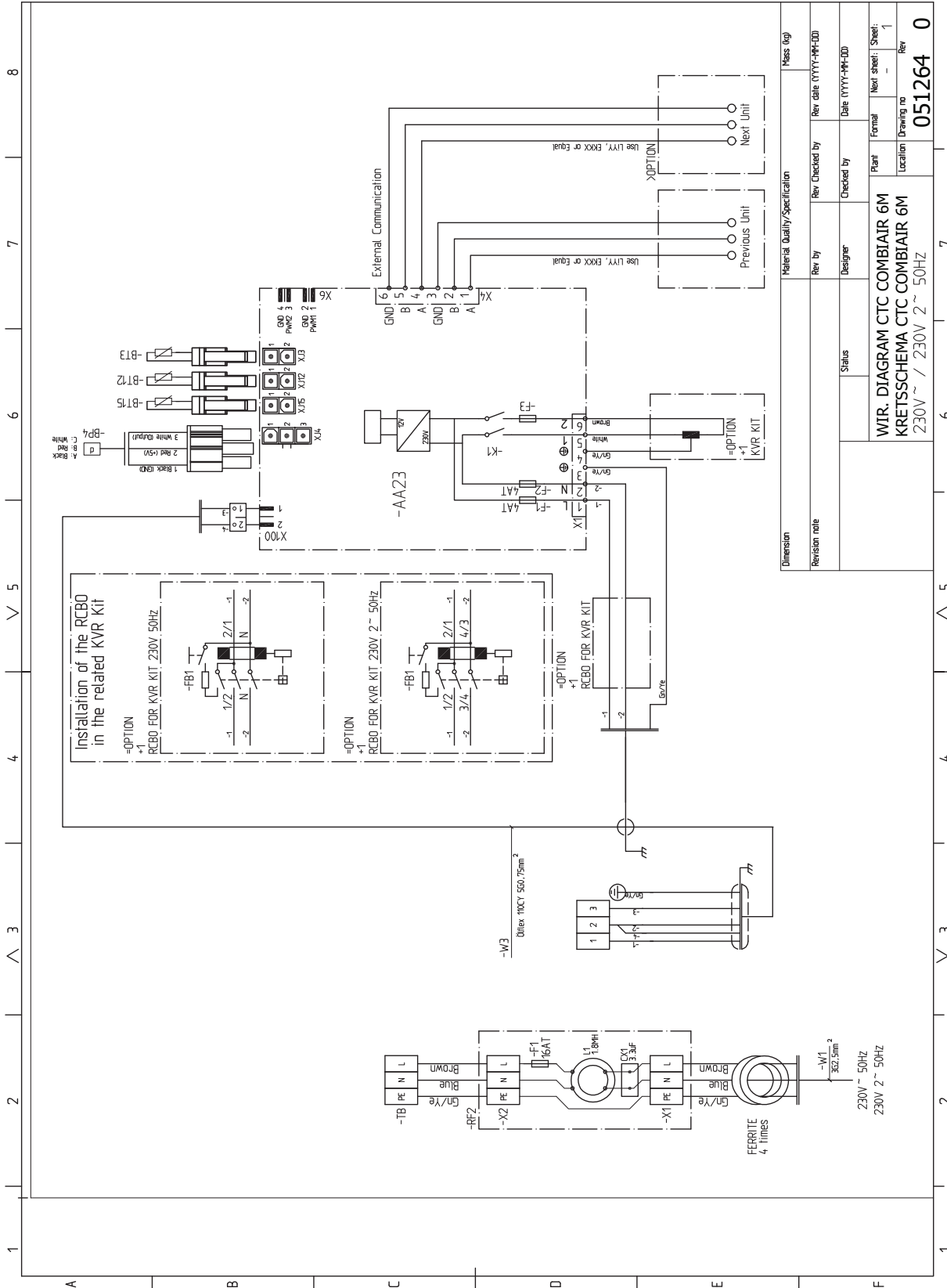

Material Quality Specification		Mass (kg)	
Rev by	Designer	Rev Checked by	Rev date (YYYY-MM-DD)
Status		Checked by	Date (YYYY-MM-DD)
WIR. DIAGRAM CTC COMBAIR 6M		Plant	Formal
KRETSSCHEMA CTC COMBAIR 6M		Location	Drawing no
230V ~ / 230V 2 ~ 50HZ		Rev sheet: 1	Sheet: 1
		Rev	0

POWER SOURCE
1 PHASE
220-240V 50Hz
220V 60Hz

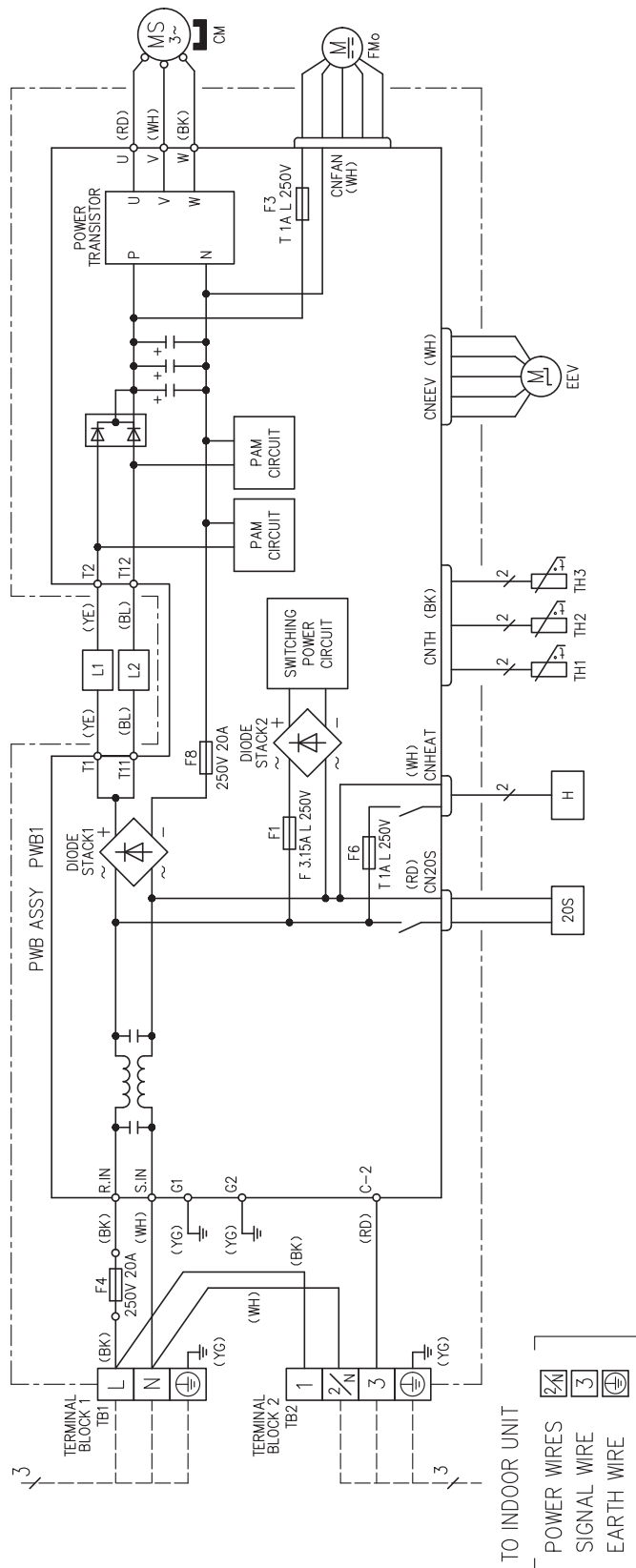

TO INDOOR UNIT



CTC CombiAir 8

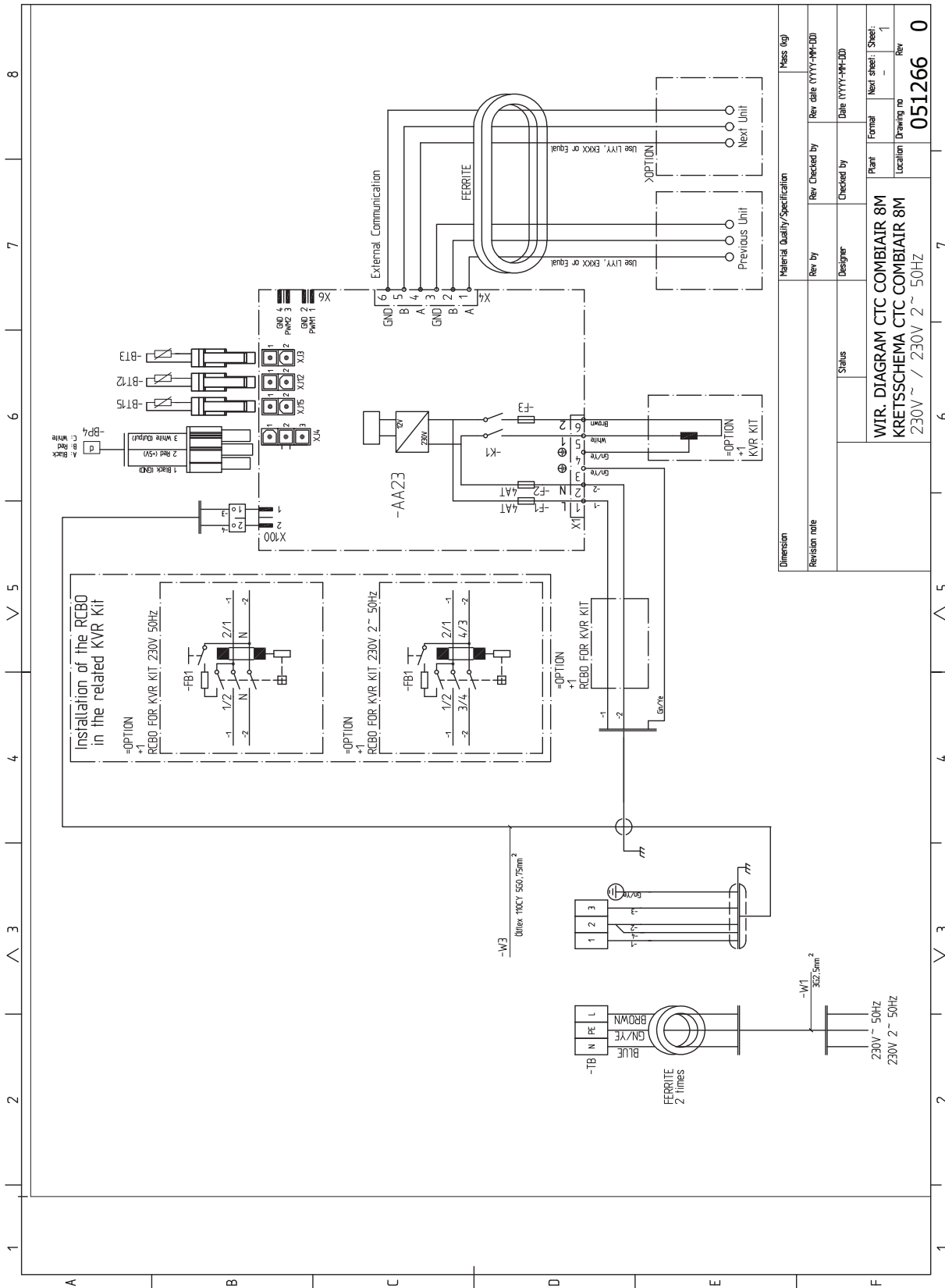

Material Quality/Specification		Mass (kg)	
Rev by	Designer	Rev checked by	Rev date (YYYY-MM-DD)
Status		Checked by	Date (YYYY-MM-DD)
WIR. DIAGRAM CTC COMBIAIR 8M		Plant	Next sheet: Sheet: 1
KRETTSCHEMA CTC COMBIAIR 8M		Location	Drawing no
230V ~ / 230V 2 ~ 50Hz			051266
		Rev	0

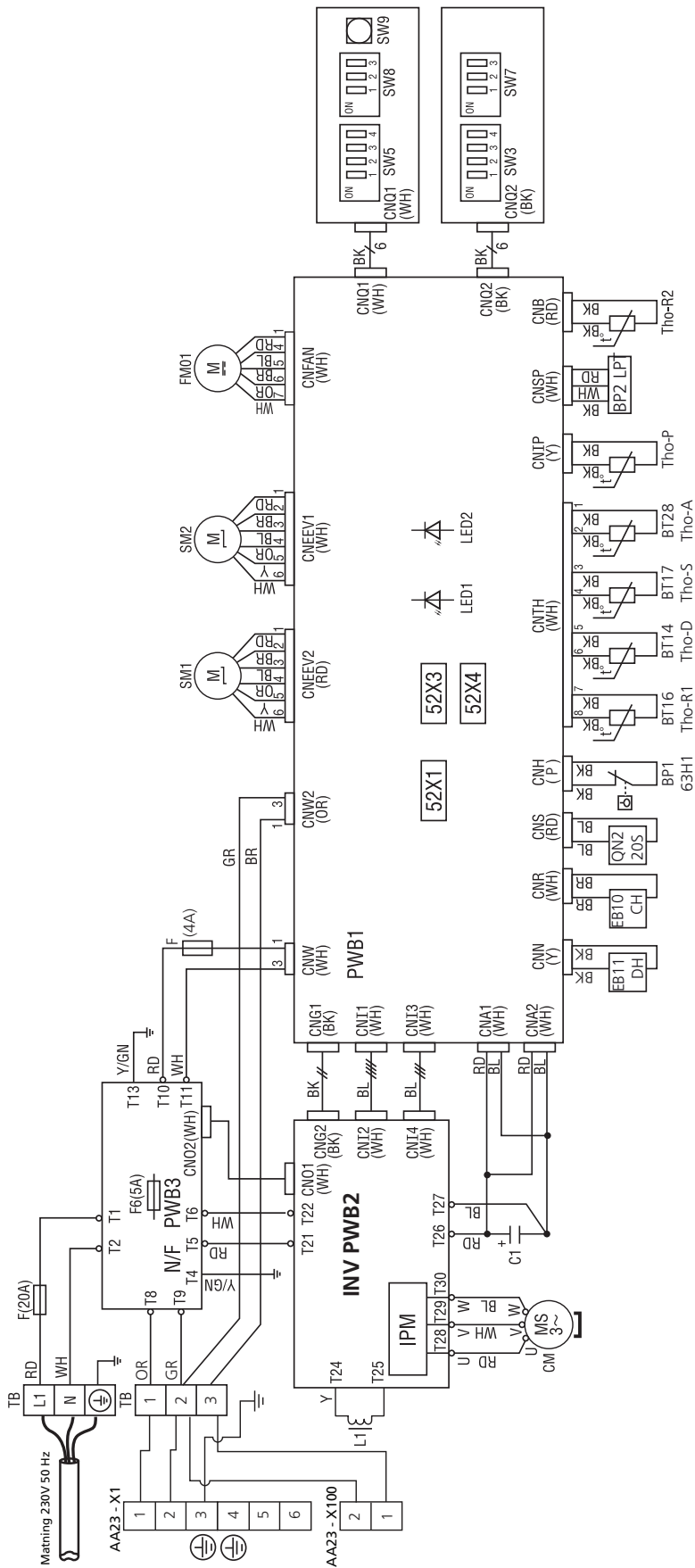

CTC CombiAir 12

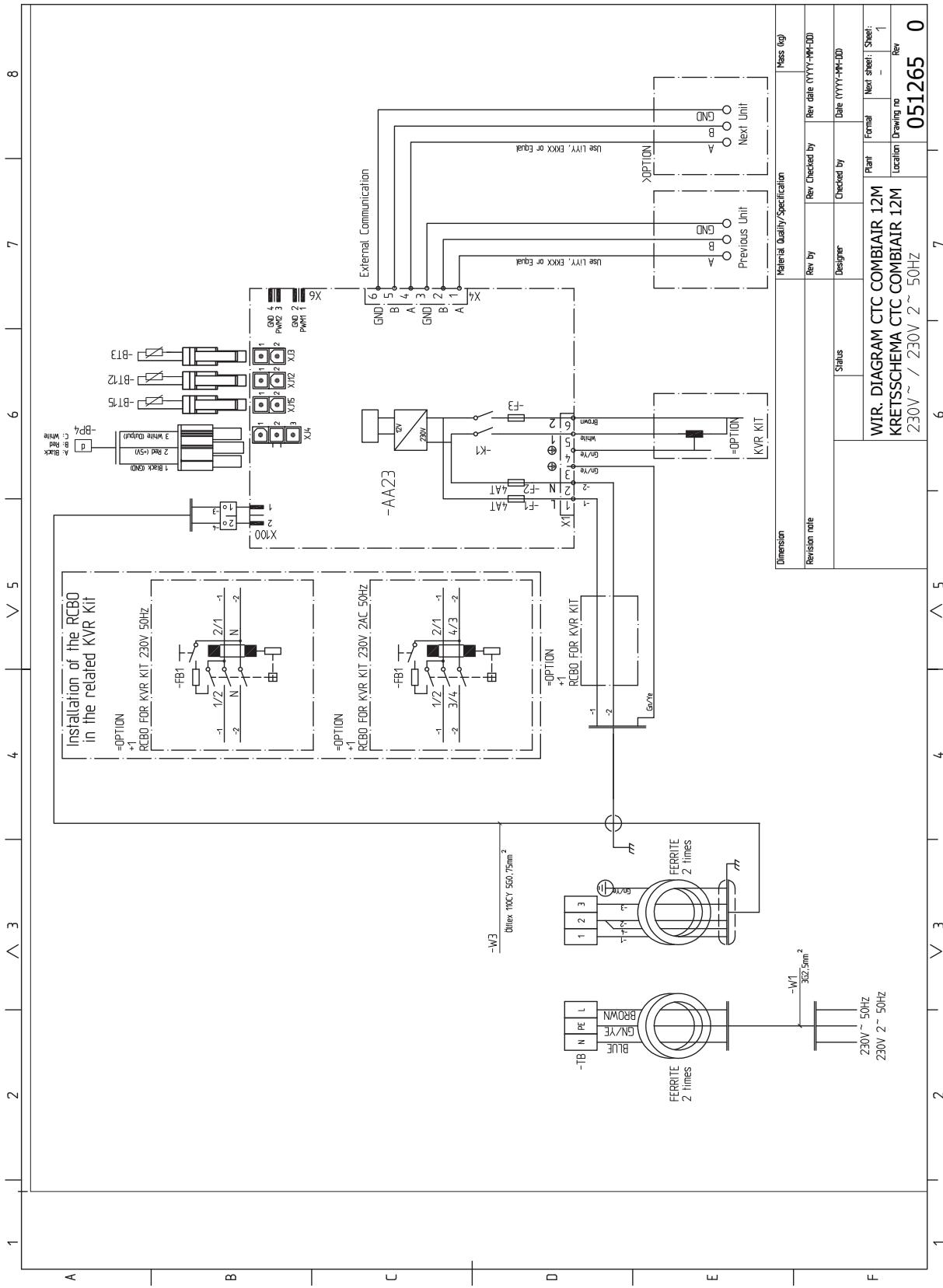

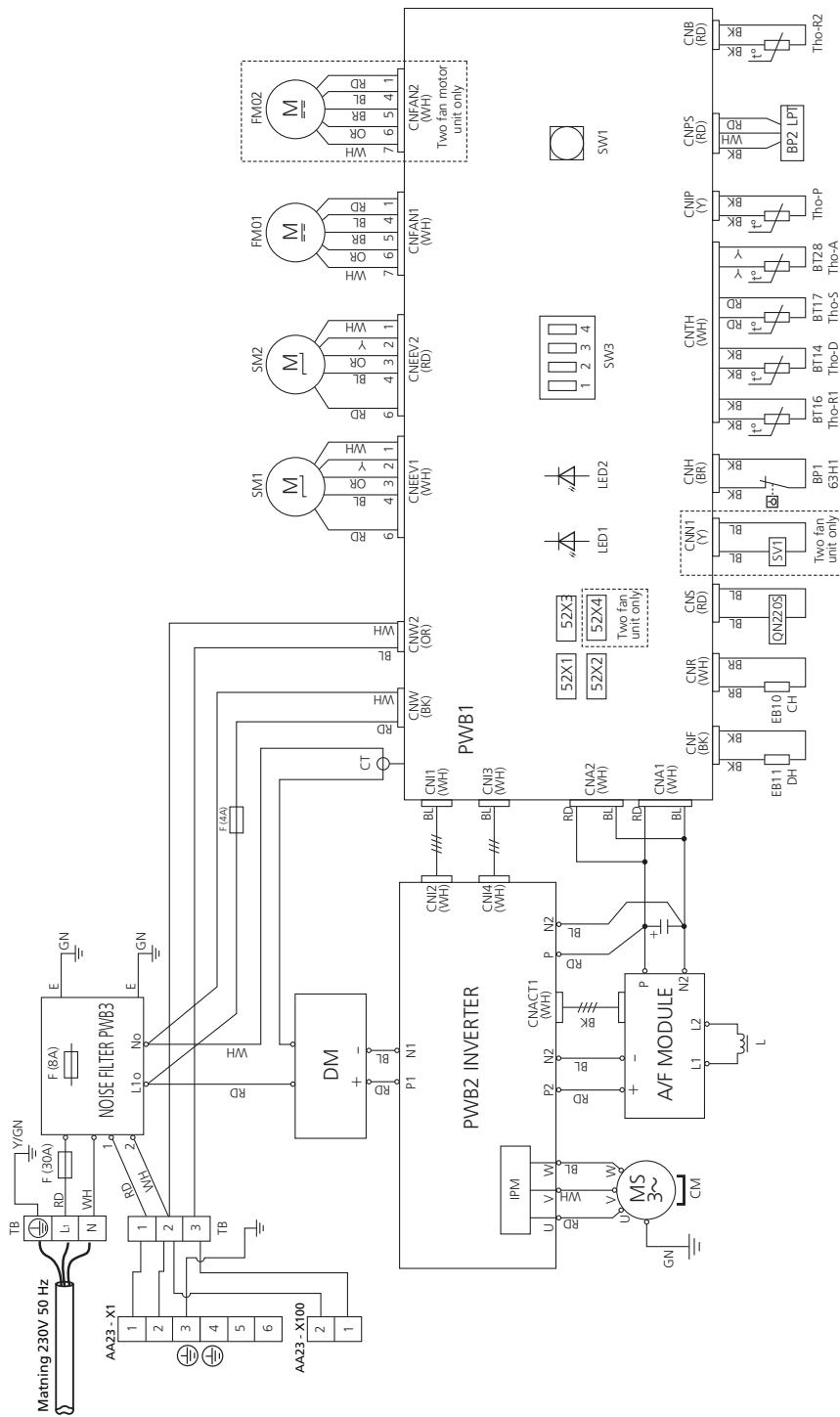

CTC CombiAir 16

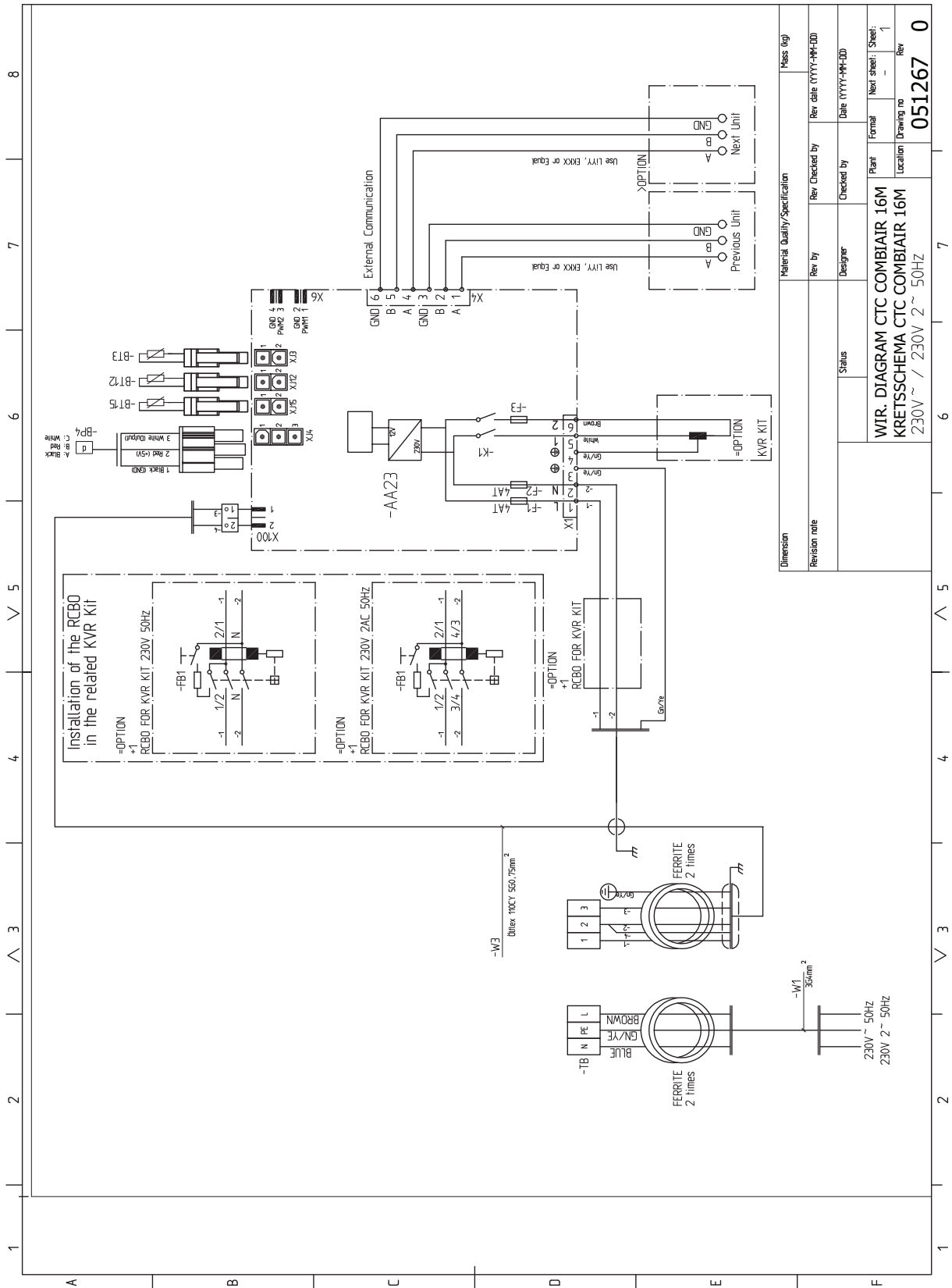

Material Quality/Specification		Mass (kg)	
Dimension		Rev by	Rev date (YYYY-MM-DD)
Revision note		Designer	Checked by
		Status	Date (YYYY-MM-DD)
		Plant	Next sheet: Sheet: 1
		Location	Drawing no
			Rev

WIR. DIAGRAM CTC COMBAIR 16M		051267	
KRETSSCHEMA CTC COMBAIR 16M		0	
230V ~ / 230V 2 ~ 50HZ			

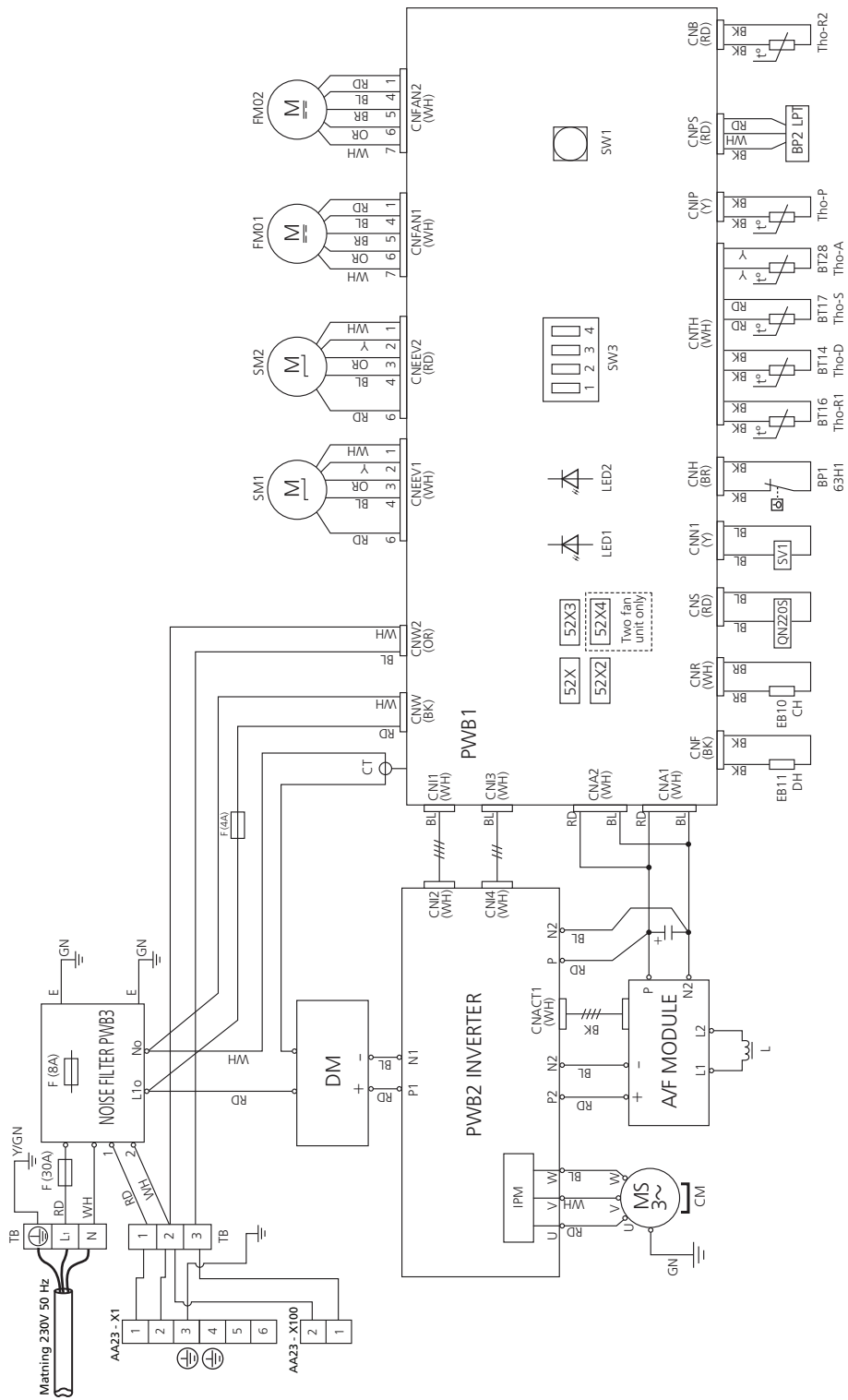

12 Item register

Item register

A

Addressing via cascade connection, 40
Adjustment, charge flow, 42
Ambient temperature sensor, 39
Assembly, 8

B

Basic actions, 44

C

Charge pump, 28
Commissioning and adjusting, 41
 Adjustment, charge flow, 42
 Compressor heater, 41
 Filling and venting the heating medium system, 41
 Preparations, 41
 Readjusting, heating medium side, 42
 Start-up and inspection, 42
Communication, 39
Compressor heater, 41
Condensate drip tray, 10
Connecting accessories, 29
Connections, 33
Connection to board (AA23), 47
Connection to board (PWB1), 46
Control, 43
CTC CombiAir does not communicate, 44
CTC CombiAir is not operational, 44

D

Delivery and handling, 8
 Assembly, 8
 Condensate drip tray, 10
 Installation area, 9
 Removing the covers, 12
 Removing the front panel, 13
 Removing the side panel, 14
 Supplied components, 11
 Transport and storage, 8
Dimensions and setting-out coordinates, 53
Disturbances in comfort, 44
 Troubleshooting, 44
Docking alternatives, 29

E

Electrical circuit diagram, 69
Electrical connection, 22
Electrical connections, 30
 Addressing via cascade connection, 40
 Ambient temperature sensor, 39
 Communication, 39
 Connecting accessories, 29
 Connections, 33
 External heating cable (KVR) (Accessory), 37
 General, 30
 Power connection, 33
Energy labelling, 64
 Data for energy efficiency of the package, 64
 Information sheet, 64
 Technical documentation, 65
Environmental information, 5
External heating cable (KVR)(Accessory), 37

F

Filling and venting the heating medium system, 41

G

General, 27, 30

H

High room temperature, 44

I

Important information, 4
 Environmental information, 5
 Inspection of the installation, 6
 Recovery, 4
 Safety information, 4
 Safety precautions, 4
 Serial number, 4
Inspection of the installation, 6
Installation area, 9

L

Large amount of water below CTC CombiAir , 44
List of components, 21
Low hot water temperature or no hot water, 44
Low room temperature, 44

M

Marking, 4

P

Pipe connections, 27
 Charge pump, 28
 Docking alternatives, 29
 General, 27
 Pipe connections flex hose, 28
 Pipe coupling heating medium circuit, 27
 Pressure drop diagram, 28
 Water volumes, 27
Pipe connections flex hose, 28
Pipe coupling heating medium circuit, 27
Power connection, 33
Preparations, 41
Pressure drop diagram, 28

R

Readjusting, heating medium side, 42
Recovery, 4
Removing the covers, 12
Removing the front panel, 13
Removing the side panel, 14

S

Safety information, 4
 Marking, 4
 Symbols, 4
Sensor data, 25
Sensor placement, 45
 Connection to board (AA23), 47
 Connection to board (PWB1), 46
 Sensor placement in CTC CombiAir , 48
 Sensors etc., 45
Sensor placement in CTC CombiAir , 48
Sensors etc., 45
Serial number, 4
Sound levels, 57
Start-up and inspection, 42
Supplied components, 11
Symbols, 4

T

Technical data, 53
 Dimensions and setting-out coordinates, 53
 Electrical circuit diagram, 69
 Sound pressure levels, 57
 Technical Data, 58
Technical Data, 58

- The heat pump design, 15
 - Component locations, 15
 - Electrical components, 25
 - Electrical connection, 22
 - List of components, 21
 - Sensor data, 25
- Transport and storage, 8
- Troubleshooting, 44
 - Basic actions, 44
 - CTC CombiAir does not communicate, 44
 - CTC CombiAir is not operational, 44
 - High room temperature, 44
 - Large amount of water below CTC CombiAir , 44
 - Low hot water temperature or no hot water, 44
 - Low room temperature, 44
 - Sensor placement, 45

Enertech AB
P.O Box 309
SE-341 26
Ljungby, Sweden
www.ctc.se



16230559